



YUANTAI CRANE MACHINERY



Henan Yuantai Crane Machinery import&Export Co., Ltd.

Tel: 0086-371-65760775 0086-371-65760776

Email: yuantai@ytcrane.com

Web: www.ytcrane.com



YUANTAI CRANE MACHINERY

新形象 新管理 新起点 新征程



公司简介 Company Profile

Dongqi Group is a Sino-foreign joint venture. The Group consists of subsidiaries: Henan Dongqi Machinery Co., Ltd. (manufacturing), Henan Yuantai Crane Machinery Import&Export Co., Ltd. (Foreign Trade).

Henan Dongqi Machinery Co., Ltd., with an area of 240,000m², gross investment of RMB 240 million yuan and registered capital of RMB 108 million yuan, has more than 3,600 employees, of which the number of managerial and technical personnel is 500, and of senior engineer is more than 70. It has more than 2,000sets of production and detection equipment and boasts an annual comprehensive production capacity of cranes up to 10,000-odd sets, with the output value reaching RMB 1.5 billion yuan. Having technical cooperation with many European-style famous machinery manufacturers like Britain SZW, German NORD, German SIMENS and French Schneider Electric, the company is committed itself to the innovation and development of European-style crane technology and strive to make Dongqi Group a domestic and international famous brand.

Henan Yuantai Crane Machinery Import&Export Co., Ltd consists of sales, e-commerce, service department, engage the Group's foreign trade. There are more than 300 employees in our company, 200 salesmen and 50 persons in the service department. Our customers distribute throughout the southeast Asia, Russia, east europe, the Middle east, Africa and other areas, the products are welcomed by all customers.

The company mainly manufactures such products: various European-style Bridge, gantry cranes, European-style electric block, etc. Some key core components are original Britain SZW product. The structures are manufactured by strictly following European-style technology standards, so that the overall performance reaches advanced world level. The products are widely applicable to multiple fields such as steel, electric power, petrochemical industry, machine building, war industry, warehouse logistics and papermaking. We will offer you the best designs and provide high-standard tailor-made European-style cranes with highly-efficient technology and economic index.



资质\荣誉 Qualification \ honor

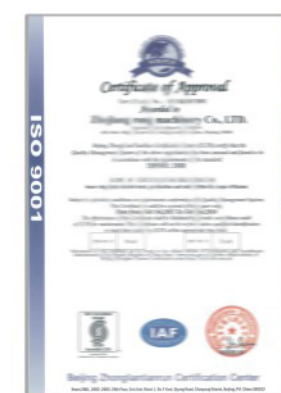
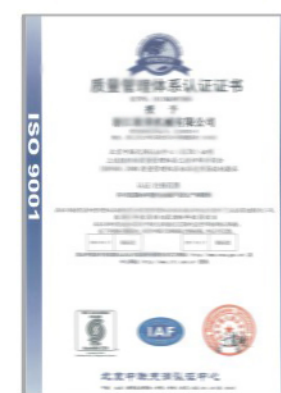
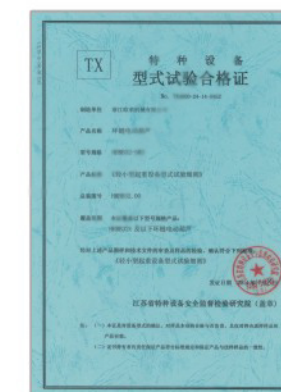
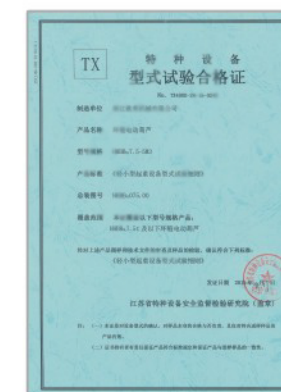
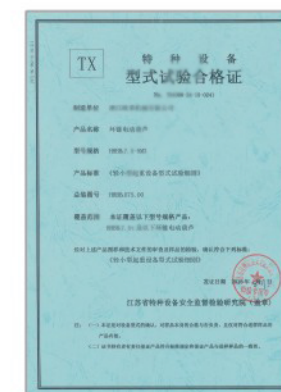
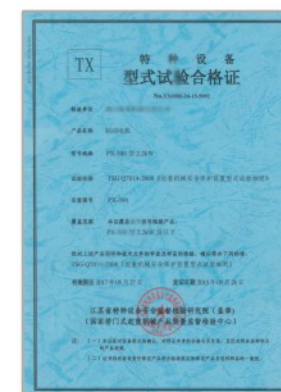

制造能力
Manufacturing capacity

创新求精 专业至益
Innovation and refinement
Professional interests



系列产品 Products

全系列产品——品种齐全，品质保证

WHOLE SERIES PRODUCTS
VARIETY PRODUCTS WITH QUALITY ASSURANCE

所有产品都凝聚了最先进的技术，严格的质量控制，为您提供最优质的产品和服务。

All products are condensed the most advanced technology and control the quality strictly we can provide you with the best quality products and service.

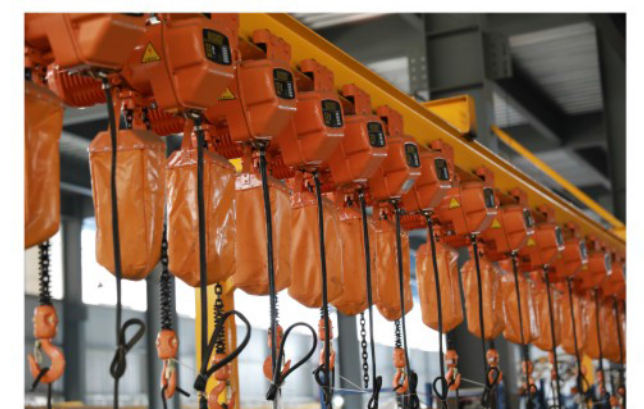
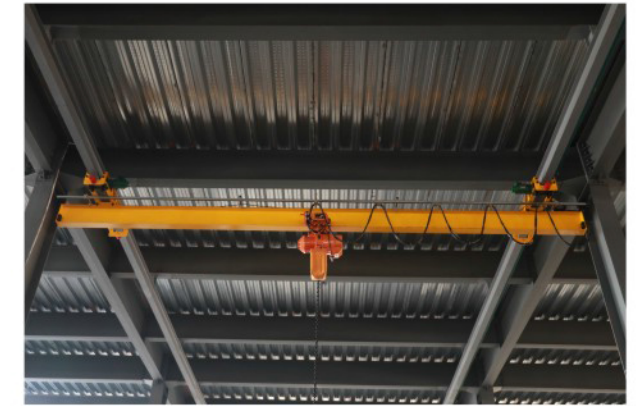

创新求精 专业至益

Innovation and refinement
Professional interests

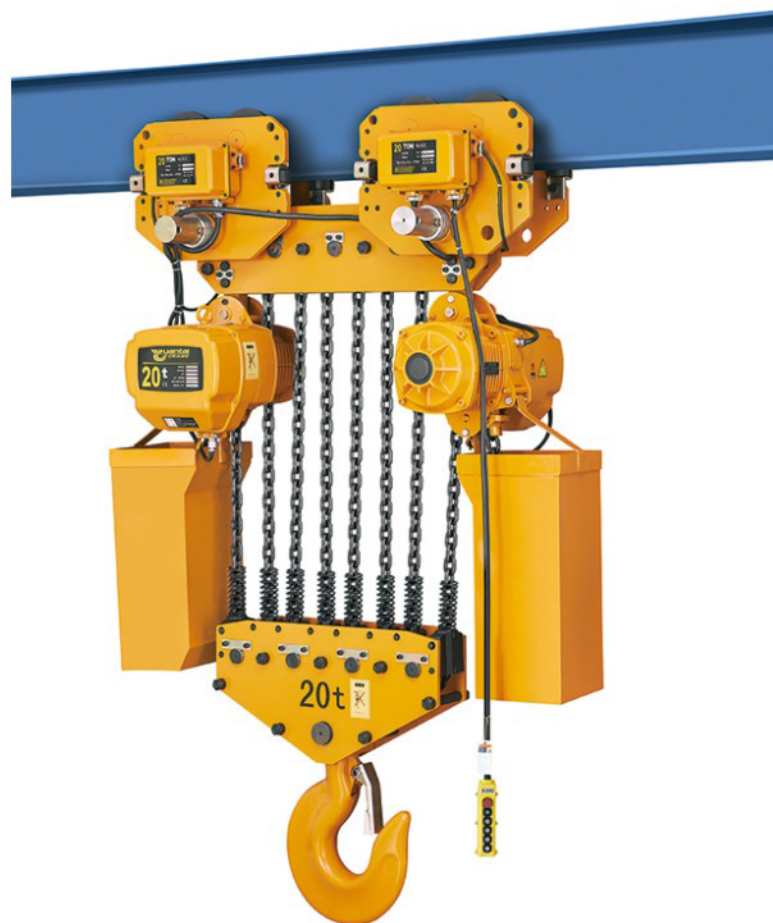

Applicable Type	Diameter (mm)D	Inside length (mm)P	Inside width (mm)A	Outside width (mm)B	Work load(kg)	Guaranteed load(KN)	Break load(KN)
HHBB0.3-01	6.3	19	7.9	20.5	1200	27	47
HHBB0.5-01	6.3	19	7.9	20.5	1200	27	47
HHBB01-01 HHBB02-02 HHBB03-03	7.1	21	8.8	23.5	1600	37	61.6
HHBB1.5-01 HHBB02-01 HHBB03-02	10.0	30	12.5	33	3200	76	125
HHBB2.5-01 HHBB03-01 HHBB05-02 HHBB7.5-03 HHBB10-04 HHBB15-06 HHBB20-08 HHBB25-10 HHBB30-12 HHBB35-16	11.2	34	14	38	3800	92	154

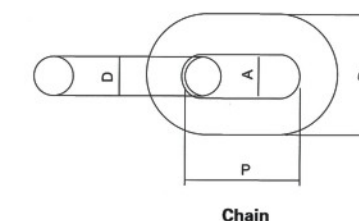

Hook: It is hot forging with perfect strength that is hard to break. The operation safety of the lower hook is ensured by its 360 degrees rotation and safety tongue piece.

Type	Load (T)	T B	A	B	C	D	E	G
HHBB	0.3,0.5	T B	27	18	25	17	32	25
	1	T B	36	25	30	24	42	32
	2	T B	46	29	39	30	49	40
	3	T B	56	36	49	34	59	48
	5	T B	67	43	57	44	60	48
	7.5	T B	82	55	80	50	90	70
	10	T B	82	55	80	50	90	70
	15,20	T B	125	90	115	85	110	80
	25,30	T B	142	95	155	98	150	115
	35	T B	210	140	210	135	200	140

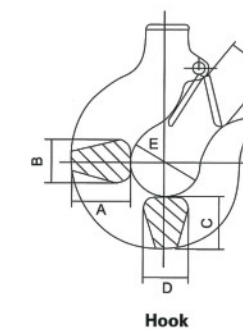

T- upper hook / B- lower hook

Type
It's the general representation form of the hoist with Hook, Hoist with Electric Trolley.

TW HHBB L 01 - 01 S D

- TW Twin Hook
- S Single speed
- D Dual speed
- L Type of super-low lifting

Code	Rated Capacity
0.3	300kg
0.5	500kg
01	1t
1.5	1.5t
02	2t
2.5	2.5t
03	3t
05	5t
7.5	7.5t
10	10t
15	15t
20	20t
25	25t
30	30t
35	35t

Code	No. of load chain
01	1
02	2
03	3
04	4
06	6
08	8
10	10
12	12
16	16

Hoist with the Hook

Hoist with Electric Trolley

HHBB Twin Hook

Twin Hook electric chain hoist, which is equipped with a single motor and two hooks, is intended to lift the hooks horizontally, equally and safely. This product is the most suitable for lifting applications requiring two lifting points for a wide load or retaining a level lifting.



HHBBTW

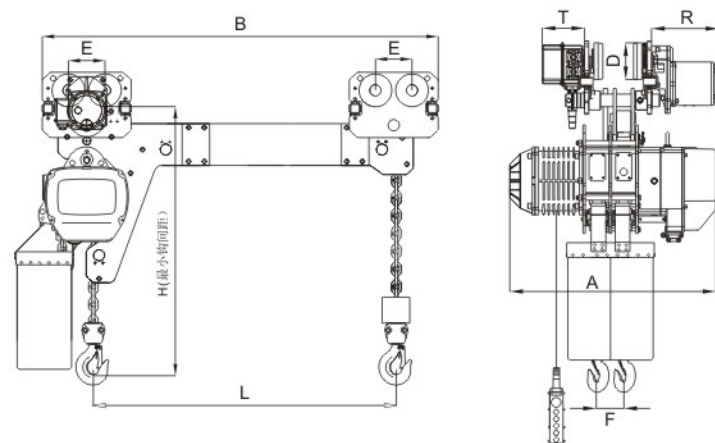

Hoist with Electric Trolley

● Size specification

Type	Capacity (Ton)	Unit(mm)								
		H	A	B	D	E	R	T	F	Chain
HHBBTW005S	250kg+250kg	665	530	L+320	95	111	230	145	62	Φ6.3*19
HHBBTW010S	500kg+500kg	675	600	L+320	95	111	230	145	68	Φ8.0*24
HHBBTW020S	1t+1t	800	705	L+330	110	127	230	145	90	Φ8.0*24
HHBBTW030S	1.5t+1.5t	840	705	L+340	125	140	230	145	90	Φ11.2*34
HHBBTW050S	2.5t+2.5t	1100	705	L+500	140	156	230	145	90	Φ11.2*34

● Technical Parameters

Type	Capacity (Ton)	Lifting Height (m)	Lifting Speed (m/min)	Lifting motor				Operating motor				I-Beam (mm)		
				Power (kw)	Rotation Speed(r/min)	Phases	Voltage(V)	Power (kw)	Rotation Speed(r/min)	Phases	Voltage(V)			
HHBBTW005S	250kg+250kg	3/9	7.2	1.1	1440	3	220-440	50/60	0.4	1440	3	220-440	50/60	80-160
HHBBTW010S	500kg+500kg	3/9	6.8	1.5	1440	3	220-440	50/60	0.4	1440	3	220-440	50/60	80-160
HHBBTW020S	1t+1t	3/9	6.6	1.5	1440	3	220-440	50/60	0.4	1440	3	220-440	50/60	82-178
HHBBTW030S	1.5t+1.5t	3/9	5.6	3	1440	3	220-440	50/60	0.4	1440	3	220-440	50/60	100-180
HHBBTW050S	2.5t+2.5t	3/9	2.8	3	1440	3	220-440	50/60	0.75	1440	3	220-440	50/60	110-180

- Shell: It is made of light aluminum alloy shell, light but hard. The cooling fin is specially designed to ensure quick heat dissipation with the rate up to 40% and continuous service. The integral enclosed structure is applicable to places like chemical plant and electroplate factory.
- 外壳：铝合金外壳，坚实而质轻。有特殊散热片，散热快，可连续使用，效率高达40%。整体密封式结构，可使用在化工厂、电镀厂等地方。
- Support frame: The loading support frame consists of two steel plates. Which is extremely sturdy.
- 支撑架：吊重支持架由两片钢板组合，非常坚固。
- Transformer: 24V / 36V transformer device. This device is used to prohi-bit unexpected accidents caused by electric leakage and guarantee the safe use while raining.
- 变压器：24V/36V变压装置。操作时，万一漏电，可防止意外事故发生，下雨时，甚至可保证安全使用。
- Side magnetic braking device: The magnetic force generator is the latest design which is featured for generating magnetic force. It allows instant brake as soon as the electric power is cut off. Thus the braking safety while loading is guaranteed.
- 磁磁刹车：最新设计的磁力产生器，其特性为产磁。可在电源切断的同时刹车，保证吊重时刹车绝对确保安全。
- Limit switch: The limit switch device is installed where the weight is lifted on and off to make the motor to stop automatically so as to prohibit the chains from exceeding for safety.
- 极限开关：吊上吊下都有极限开关装置，使自动停止，防止链条超出，确保安全。
- Chain: The chain shall adopt the imported FEC80 ultra heat-treatable Alloy steel chain. It can be safely used in poor environment such as rain, sea water and chemicals.
- 链条：采用进口FEC80超超加热处理合金钢链条。在雨水、海水、化学品及其他恶劣状况下使用安全无虑。
- Hook: It is hot forging with perfect strength that is hard to break. The operation safety of the lower hook is ensured by its 360 degrees rotation and safety tongue piece.
- 吊钩：经热锻造，强度绝佳，不易断裂。下吊钩可360°旋转，附安全舌片，确保操作安全。
- Electromagnetic contactor: Electromagnetic contactor can be used safely under high frequency.
- 电磁接触器：高效率电磁接触器，可高频使用，没有问题。
- Inverse phase sequence protecting device: It is the special electrical installation which controls the circuit not to work in case of wiring error in the power supply.
- 逆相保护装置：特殊电线装置，当电源线错误时，控制电路无法动作。
- Push button: Waterproof push button is applied. It is light and durable.
- 按钮开关：使用防水按钮开关，轻便耐用。

- Standard fittings Chain bag (1) Control cable (3m) Push-button switch (1)
- 标准配件 链条袋(1只) 控制电缆(3m) 按钮开关(1只)

Hoist with the hook



0.3-01

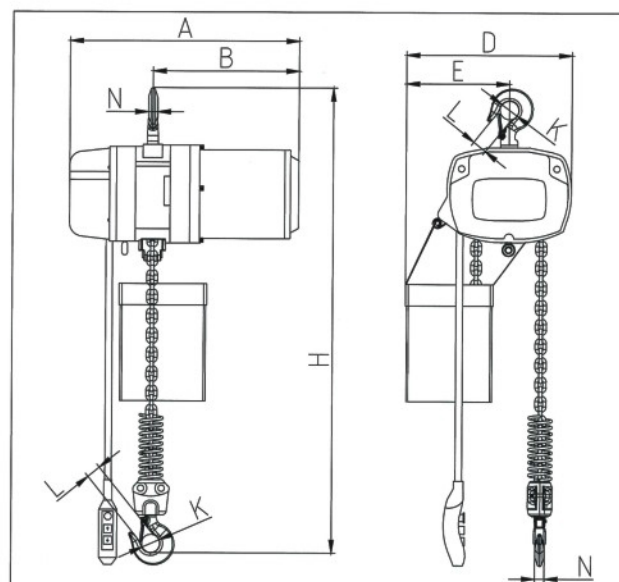

Hoist with the Hook

● Technical Parameters

Type	Capacity (Ton)	Lifting Height (m)	Lifting Speed (m/min)	Lifting motor					Operating motor					I-Beam (mm)	
				Power (kw)	Rotation Speed(r/min)	Phases	Voltage(V)	Frequency (Hz/s)	Power (kw)	Rotation Spedd(r/min)	Operating speed(m/min)	Phases	Voltage(V)		Frequency (Hz/s)
HHBB0.3-01S	0.3	3/9	7.2	0.75	1440	3	220-440	50/60	/	/	/	/	/	/	/

● Size specification

Type	Capacity (Ton)	Unit(mm)									
		H	A	B	D	E	K	L	N	Chain	
HHBB0.3-01S	0.3	530	455	210	225	120	Φ32	25	13	Φ6.3	



02-01

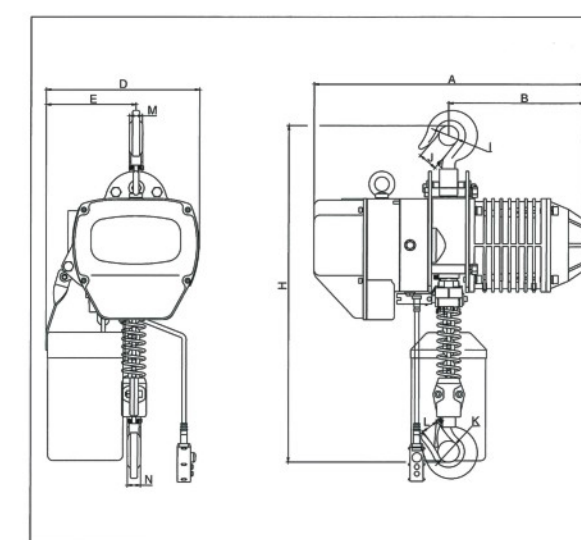

Hoist with the Hook

● Technical Parameters

Type	Capacity (Ton)	Lifting Height (m)	Lifting Speed (m/min)	Lifting motor					Operating motor					I-Beam (mm)	
				Power (kw)	Rotation Speed(r/min)	Phases	Voltage(V)	Frequency (Hz/s)	Power (kw)	Rotation Spedd(r/min)	Operating speed(m/min)	Phases	Voltage(V)		Frequency (Hz/s)
HHBB0.5-01S	0.5	3/9	7.2	1.1	1440	3	220-440	50/60	/	/	/	/	/	/	/
HHBB01-01S	1	3/9	6.8	1.5	1440	3	220-440	50/60	/	/	/	/	/	/	/
HHBB01-02S	1	3/9	3.6	1.1	1440	3	220-440	50/60	/	/	/	/	/	/	/
HHBB02-01S	2	3/9	6.6	3.0	1440	3	220-440	50/60	/	/	/	/	/	/	/
HHBB02-02S	2	3/9	3.4	1.5	1440	3	220-440	50/60	/	/	/	/	/	/	/
HHBB03-01S	3	3/9	5.6	3.0	1440	3	220-440	50/60	/	/	/	/	/	/	/
HHBB03-02S	3	3/9	3.3	3.0	1440	3	220-440	50/60	/	/	/	/	/	/	/
HHBB03-03S	3	3/9	2.2	1.5	1440	3	220-440	50/60	/	/	/	/	/	/	/
HHBB05-02S	5	3/9	2.8	3.0	1440	3	220-440	50/60	/	/	/	/	/	/	/

● Size specification

Type	Capacity (Ton)	Unit(mm)											
		H	A	B	D	E	I	J	K	L	M	N	Chain
HHBB0.5-01S	0.5	550	460	230	280	160	Φ32	25	Φ32	Φ25	17	17	Φ6.3
HHBB01-01S	1	600	520	260	300	176	Φ40	31	Φ40	Φ31	24	24	Φ7.1
HHBB01-02S	1	670	460	230	280	205	Φ40	31	Φ40	Φ31	24	24	Φ6.3
HHBB02-01S	2	800	620	310	430	265	Φ49	35	Φ49	Φ35	30	30	Φ10.0
HHBB02-02S	2	750	520	260	300	230	Φ49	35	Φ49	Φ35	30	30	Φ7.1
HHBB03-01S	3	845	620	310	430	265	Φ59	42	Φ59	Φ42	35	35	Φ11.2
HHBB03-02S	3	950	620	310	430	320	Φ59	42	Φ59	Φ42	35	35	Φ10.0
HHBB03-03S	3	1000	520	260	350	280	Φ59	42	Φ59	Φ42	35	35	Φ7.1
HHBB05-02S	5	1030	620	310	430	325	Φ60	45	Φ60	Φ45	43	43	Φ11.2

Hoist with Manual Trolley



0.5-01

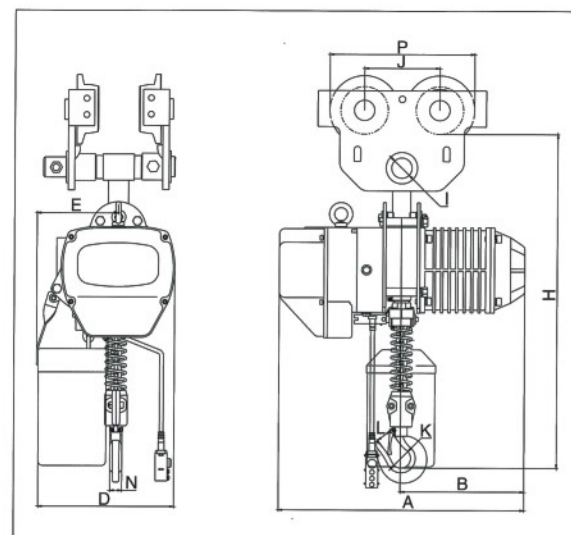

Hoist with Electric Trolley



05-02

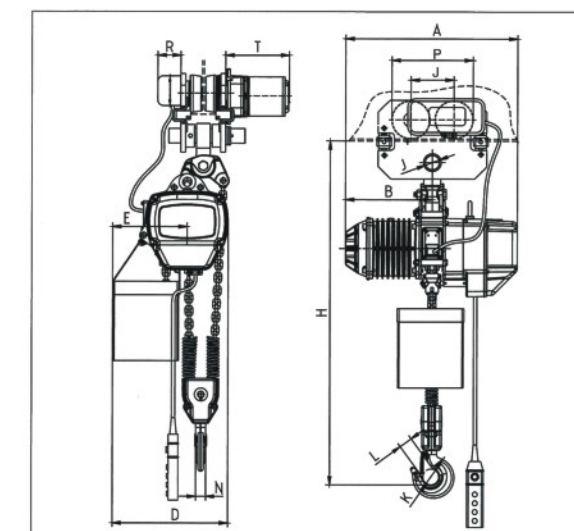

Hoist With Manual Trolley

● Technical Parameters

Type	Capacity (Ton)	Lifting Height (m)	Lifting Speed (m/min)	Lifting motor					Operating motor					I-Beam (mm)	
				Power (kw)	Rotation Speed(r/min)	Phases	Voltage(V)	Frequency (Hz/s)	Power (kw)	Rotation Speed(r/min)	Operating speed(m/min)	Phases	Voltage(V)		Frequency (Hz/s)
HHBB0.5-01S	0.5	3/9	7.2	1.1	1440	3	220-440	50/60	/	/	/	/	/	/	50-102
HHBB01-01S	1	3/9	6.8	1.5	1440	3	220-440	50/60	/	/	/	/	/	/	68-130
HHBB01-02S	1	3/9	3.6	1.1	1440	3	220-440	50/60	/	/	/	/	/	/	68-130
HHBB02-01S	2	3/9	6.6	3.0	1440	3	220-440	50/60	/	/	/	/	/	/	82-153
HHBB02-02S	2	3/9	3.4	1.5	1440	3	220-440	50/60	/	/	/	/	/	/	82-153
HHBB03-01S	3	3/9	5.6	3.0	1440	3	220-440	50/60	/	/	/	/	/	/	82-153
HHBB03-02S	3	3/9	3.3	3.0	1440	3	220-440	50/60	/	/	/	/	/	/	82-163
HHBB03-03S	3	3/9	2.2	1.5	1440	3	220-440	50/60	/	/	/	/	/	/	110-178
HHBB05-02S	5	3/9	2.8	3.0	1440	3	220-440	50/60	/	/	/	/	/	/	100-178

● Size specification

Type	Capacity (Ton)	Unit(mm)											Chain
		H	A	B	D	E	I	J	P	K	L	N	
HHBB0.5-01S	0.5	580	460	230	280	160	φ28	91	163	φ32	25	17	φ6.3
HHBB01-01S	1	635	520	260	300	176	φ30	115	220	φ40	31	24	φ7.1
HHBB01-02S	1	640	460	230	280	205	φ30	115	220	φ40	31	24	φ6.3
HHBB02-01S	2	764	620	310	430	265	φ36	157	277	φ49	36	30	φ10.0
HHBB02-02S	2	730	520	260	300	230	φ36	138	265	φ49	35	30	φ7.1
HHBB03-01S	3	830	620	310	430	265	φ43	178	332	φ59	42	35	φ10.0
HHBB03-02S	3	940	620	310	430	320	φ43	178	332	φ59	42	35	φ10.0
HHBB03-03S	3	980	520	260	350	280	φ43	178	332	φ59	42	35	φ7.1
HHBB05-02S	5	1007	620	310	430	325	φ43	178	332	φ60	45	43	φ11.2

Hoist with Electric Trolley

● Technical Parameters

Type	Capacity (Ton)	Lifting Height (m)	Lifting Speed (m/min)	Lifting motor					Operating motor					I-Beam (mm)	
				Power (kw)	Rotation Speed(r/min)	Phases	Voltage(V)	Frequency (Hz/s)	Power (kw)	Rotation Speed(r/min)	Operating speed(m/min)	Phases	Voltage(V)		Frequency (Hz/s)
HHBB0.5-01S	0.5	3/9	7.2	1.1	1440	3	220-440	50/60	0.2	1440	14	3	220-440	50/60	70-130
HHBB01-01S	1	3/9	6.8	1.5	1440	3	220-440	50/60	0.4	1440	10/20	3	220-440	50/60	80-160
HHBB01-02S	1	3/9	3.6	1.1	1440	3	220-440	50/60	0.4	1440	10/20	3	220-440	50/60	80-160
HHBB02-01S	2	3/9	6.6	3.0	1440	3	220-440	50/60	0.4	1440	10/20	3	220-440	50/60	82-178
HHBB02-02S	2	3/9	3.4	1.5	1440	3	220-440	50/60	0.4	1440	10/20	3	220-440	50/60	82-178
HHBB03-01S	3	3/9	5.6	3.0	1440	3	220-440	50/60	0.4	1440	10/20	3	220-440	50/60	100-180
HHBB03-02S	3	3/9	3.3	3.0	1440	3	220-440	50/60	0.4	1440	11/21	3	220-440	50/60	100-180
HHBB03-03S	3	3/9	2.2	1.5	1440	3	220-440	50/60	0.4	1440	11/21	3	220-440	50/60	100-180
HHBB05-02S	5	3/9	2.8	3.0	1440	3	220-440	50/60	0.75	1440	10/20	3	220-440	50/60	110-180

● Size specification

Type	Capacity (Ton)	Unit(mm)											Chain		
		H	A	B	D	E	I	J	P	K	L	N		R	T
HHBB0.5-01S	0.5	630	460	230	280	160	φ31	100	162	φ32	25	17	142	150	φ6.3
HHBB01-01S	1	650	520	260	300	176	φ31	111	206	φ40	31	24	142	231	φ7.1
HHBB01-02S	1	640	460	230	280	205	φ31	111	206	φ40	31	24	142	230	φ6.3
HHBB02-01S	2	770	620	310	430	265	φ36	127	237	φ49	36	30	142	231	φ10.0
HHBB02-02S	2	740	520	260	300	230	φ36	127	237	φ49	35	30	142	231	φ7.1
HHBB03-01S	3	840	620	310	430	265	φ43	140	265	φ59	42	35	142	231	φ11.2
HHBB03-02S	3	940	620	310	430	320	φ43	140	265	φ59	42	35	142	231	φ10.0
HHBB03-03S	3	920	520	260	350	280	φ43	140	265	φ59	42	35	142	231	φ7.1
HHBB05-02S	5	1015	620	310	430	325	φ54	156	296	φ60	45	43	142	231	φ11.2



7.5-03

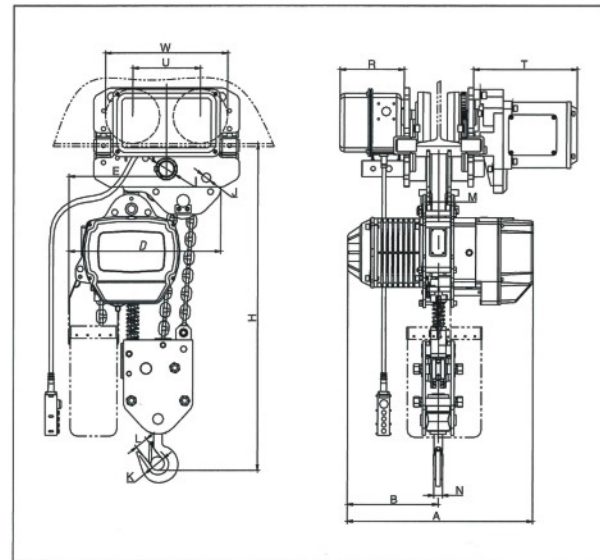

Hoist with Electric Trolley

● Technical Parameters

Type	Capacity (Ton)	Lifting Height (m)	Lifting Speed (m/min)	Lifting motor					Operating motor					I-Beam (mm)	
				Power (kw)	Rotation Speed(r/min)	Phases	Voltage(V)	Frequency (Hz/s)	Power (kw)	Rotation Speed(r/min)	Operating speed(m/min)	Phases	Voltage(V)		Frequency (Hz/s)
HHBB7.5-03S	7.5	3/9	1.8	3.0	1440	3	220-440	50/60	0.75	1440	10	3	220-440	50/60	120-180

● Size specification

Type	Capacity (Ton)	Unit(mm)															
		H	A	B	D	E	I	J	K	L	M	N	W	U	R	T	Chain
HHBB7.5-03S	7.5	1200	620	310	500	320	Φ70	Φ37	Φ90	65	85	50	366	191	142	231	Φ11.2



10-04

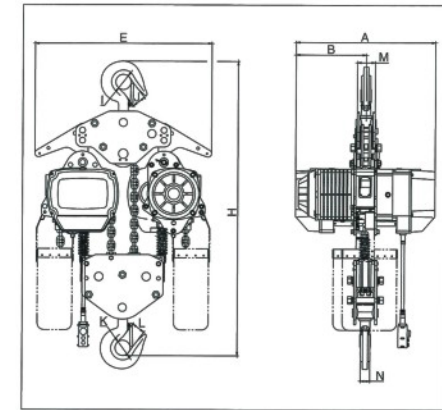

Hoist with the Hook

● Technical Parameters

Type	Capacity (Ton)	Lifting Height (m)	Lifting Speed (m/min)	Lifting motor					Operating motor					I-Beam (mm)	
				Power (kw)	Rotation Speed(r/min)	Phases	Voltage(V)	Frequency (Hz/s)	Power (kw)	Rotation Speed(r/min)	Operating speed(m/min)	Phases	Voltage(V)		Frequency (Hz/s)
HHBB10-04S	10	3/9	2.8	3.0x2	1440	3	220-440	50	/	/	/	/	/	/	/

● Size specification

Type	Capacity (Ton)	Unit(mm)										
		H	A	B	E	I	J	K	M	L	N	Chain
HHBB10-04S	10	1400	630	315	890	Φ90	70	Φ90	107	65	50	Φ11.2



10-04

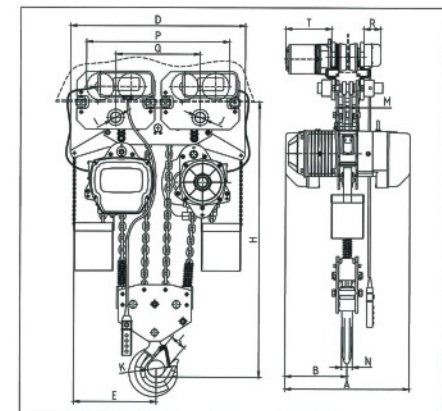

Hoist with Electric Trolley

● Technical Parameters

Type	Capacity (Ton)	Lifting Height (m)	Lifting Speed (m/min)	Lifting motor					Operating motor					I-Beam (mm)	
				Power (kw)	Rotation Speed(r/min)	Phases	Voltage(V)	Frequency (Hz/s)	Power (kw)	Rotation Speed(r/min)	Operating speed(m/min)	Phases	Voltage(V)		Frequency (Hz/s)
HHBB10-04S	10	3/9	2.8	3.0x2	1440	3	220-440	50	0.75	1440	10	3	220-440	50	150-220

● Size specification

Type	Capacity (Ton)	Unit(mm)															
		H	A	B	D	E	I	J	K	L	M	N	P	Q	R	T	Chain
HHBB10-04S	10	1200	630	315	860	430	Φ54	Φ54	Φ90	65	85	50	726	430	142	231	Φ11.2



15-06

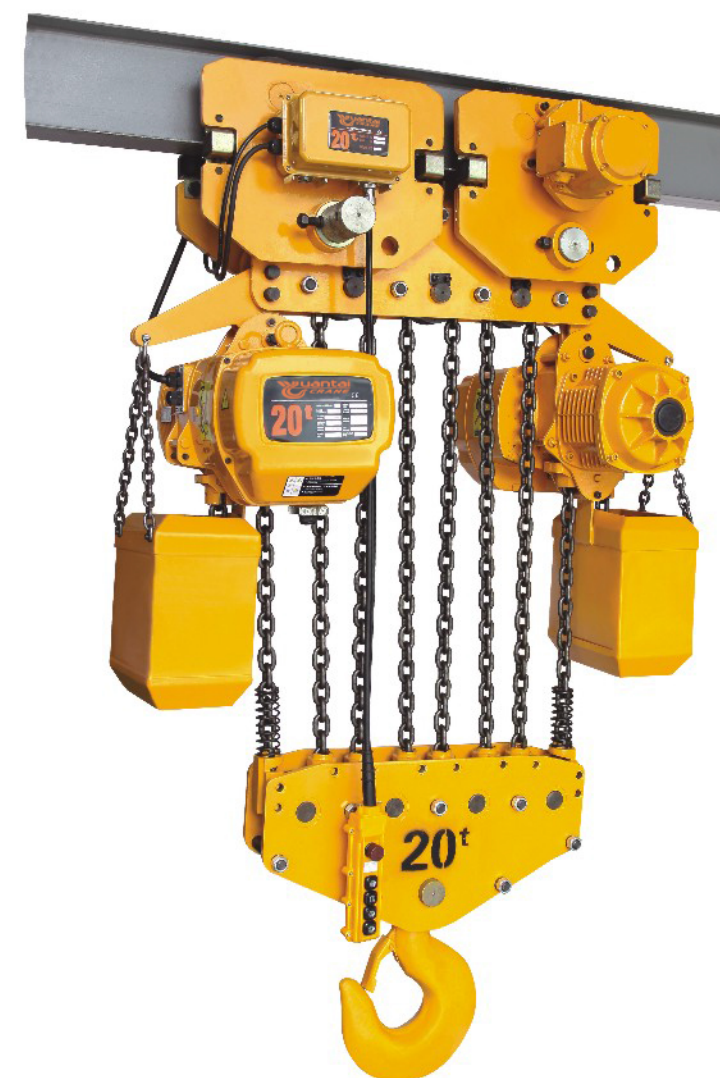
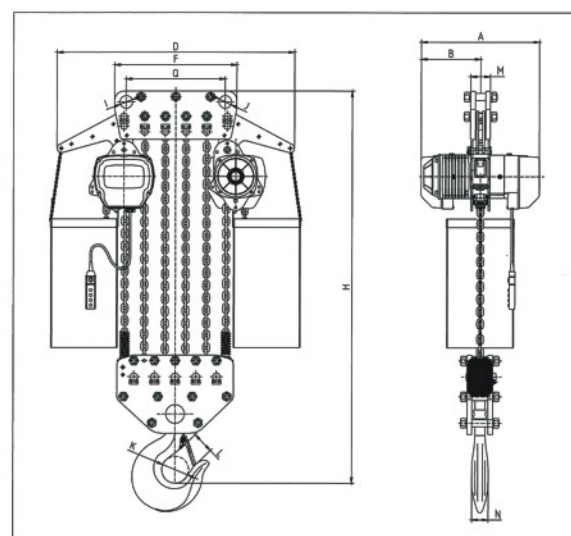

20-08

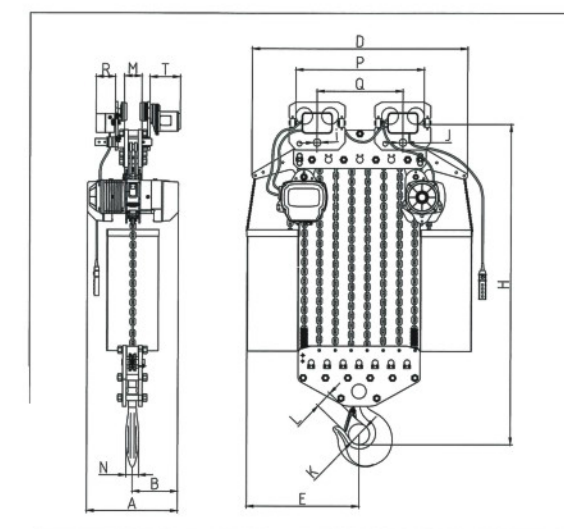

● Technical Parameters

Type	Capacity (Ton)	Lifting Height (m)	Lifting Speed (m/min)	Lifting motor					Operating motor					I-Beam (mm)	
				Power (kw)	Rotation Speed(r/min)	Phases	Voltage(V)	Frequency (Hz/s)	Power (kw)	Rotation Speed(r/min)	Operating speed(m/min)	Phases	Voltage(V)		Frequency (Hz/s)
HHBB15-06S	15	3/9	1.8	3.0x2	1440	3	220-440	50/60	0.75x2	1440	11/21	3	220-440	50/60	150-220

● Size specification

Type	Capacity (Ton)	Unit(mm)													
		H	A	B	D	E	I	J	K	L	N	M	Q	Chain	
HHBB15-06S	15	1310	630	315	1070	590	Φ70	Φ70	Φ110	80	85	88	520	Φ11.2	

● Technical Parameters

Type	Capacity (Ton)	Lifting Height (m)	Lifting Speed (m/min)	Lifting motor					Operating motor					I-Beam (mm)	
				Power (kw)	Rotation Speed(r/min)	Phases	Voltage(V)	Frequency (Hz/s)	Power (kw)	Rotation Spedd(r/min)	Operating speed(m/min)	Phases	Voltage(V)		Frequency (Hz/s)
HHBB20-08S	20	3/9	1.4	3.0x2	1440	3	220-440	50/60	0.75x2	1440	11/21	3	220-440	50/60	150-220

● Size specification

Type	Capacity (Ton)	Unit(mm)														
		H	A	B	D	I	J	N	K	M	P	Q	R	T	L	Chain
HHBB20-08S	20	1470	630	315	1260	Φ70	Φ70	85	Φ110	88	886	520	142	231	80	Φ11.2



25-10

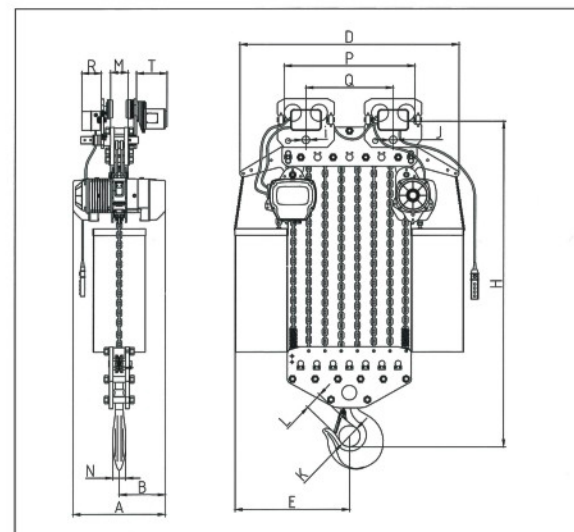

30-12

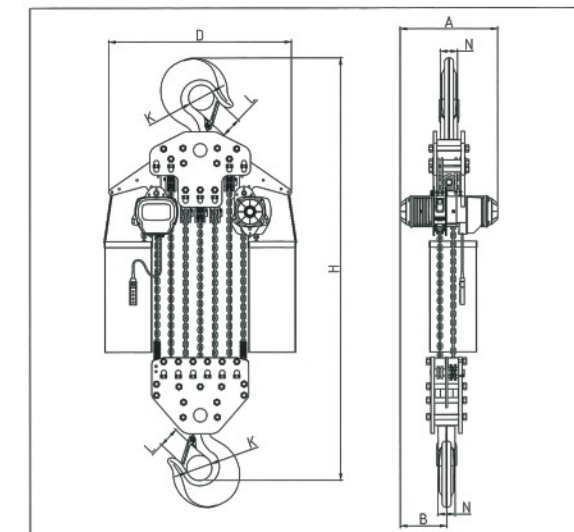

● Technical Parameters

Type	Capacity (Ton)	Lifting Height (m)	Lifting Speed (m/min)	Lifting motor					Operating motor					I-Beam (mm)	
				Power (kw)	Rotation Speed(r/min)	Phases	Voltage(V)	Frequency (Hz/s)	Power (kw)	Rotation Speed(r/min)	Operating speed(m/min)	Phases	Voltage(V)		Frequency (Hz/s)
HHBB25-10S	25	3/9	1.1	3.0x2	1440	3	220-440	50/60	0.75x2	1440	11/21	3	220-440	50/60	150-220

● Size specification

Type	Capacity (Ton)	Unit(mm)														
		H	A	B	D	I	J	N	K	M	P	Q	R	T	L	Chain
HHBB25-10S	25	1580	630	315	1450	Φ75	Φ75	95	Φ140	96	1080	680	142	231	100	Φ11.2

● Technical Parameters

Type	Capacity (Ton)	Lifting Height (m)	Lifting Speed (m/min)	Lifting motor					Operating motor					I-Beam (mm)	
				Power (kw)	Rotation Speed(r/min)	Phases	Voltage(V)	Frequency (Hz/s)	Power (kw)	Rotation Spedd(r/min)	Operating speed(m/min)	Phases	Voltage(V)		Frequency (Hz/s)
HHBB30-12S	30	3/9	0.9	3.0x2	1440	3	220-440	50/60	0.75x2	1440	11/21	3	220-440	50/60	150-220

● Size specification

Type	Capacity (Ton)	Unit(mm)									
		H	A	B	D	K	L	M	N	Chain	
HHBB30-12S	30	1640	860	430	1380	Φ145	100	228	98	Φ11.2	



35-16

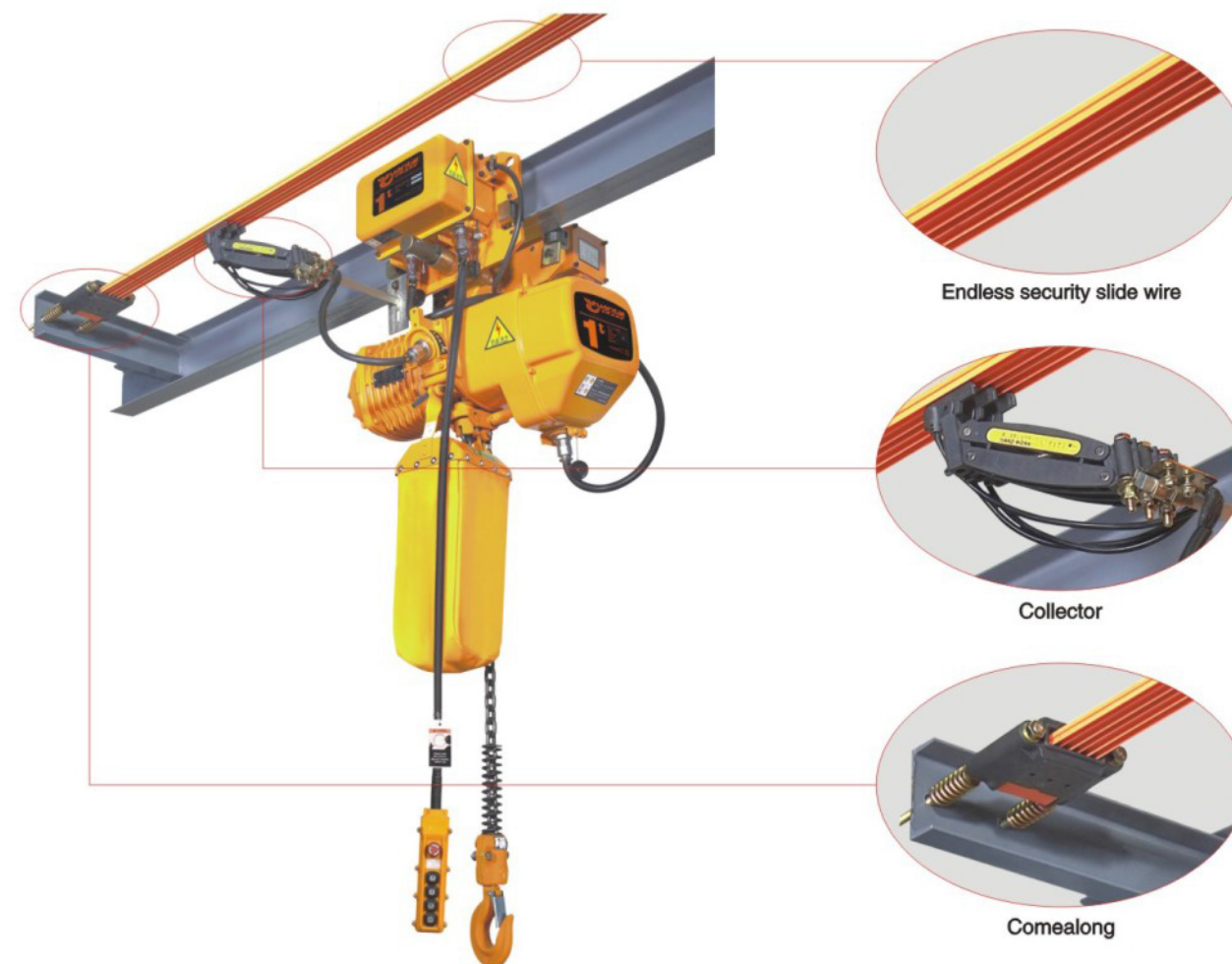
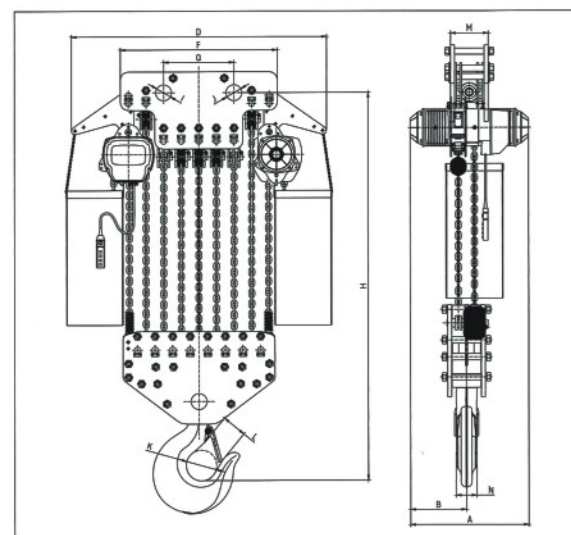

Hoist Parameters Of Dual Speeds

Item	Type	Speed(r/min)	Power(kw)	RotationSpedd(r/min)
1	HHBB0.5-01D	7.2/2.4	1.1/0.37	980/2830
2	HHBB01-02D	3.6/1.2	1.1/0.37	980/2830
3	HHBB01-01D	6.9/2.3	1.5/0.6	980/2830
4	HHBB02-01D	6.6/2.2	3.0/1.0	980/2830
5	HHBB02-02D	3.3/1.1	1.5/0.6	980/2830
6	HHBB03-01D	5.6/1.8	3.0/1.0	980/2830
7	HHBB03-02D	3.3/1.1	3.0/1.0	980/2830
8	HHBB03-03D	2.3/0.8	1.5/0.6	980/2830
9	HHBB05-02D	2.8/0.9	3.0/1.0	980/2830
10	HHBB7.5-03D	1.8/0.6	3.0/1.0	980/2830
11	HHBB10-04D	2.8/0.9	3.0/1.0x2	980/2830

● Technical Parameters

Type	Capacity (Ton)	Lifting Height (m)	Lifting Speed (m/min)	Lifting motor					Operating motor					I-Beam (mm)	
				Power (kw)	Rotation Speed(r/min)	Phases	Voltage(V)	Frequency (Hz/s)	Power (kw)	Rotation Spedd(r/min)	Operating speed(m/min)	Phases	Voltage(V)		Frequency (Hz/s)
HHBB35-16S	35	3/9	0.7	3.0x2	1440	3	220-440	50/60	0.75x2	1440	11/21	3	220-440	50/60	150-220

● Size specification

Type	Capacity (Ton)	Unit(mm)												
		H	A	B	D	F	Q	K	L	M	N	J	I	Chain
HHBB35-16S	35	1790	860	430	1600	990	440	φ 200	140	235	135	φ 100	φ 100	φ 11.2

Super-low lifting loop chain electric hoist



Product features:

It is typical of unique optimal structure in shortening the distance between the machine body and the beam tracks, applicable to operations inside fairly low buildings, especially suitable for use in temporarily erected plant buildings or on the sites where expansion of effective hoisting spaces inside the buidings is required.

01-01

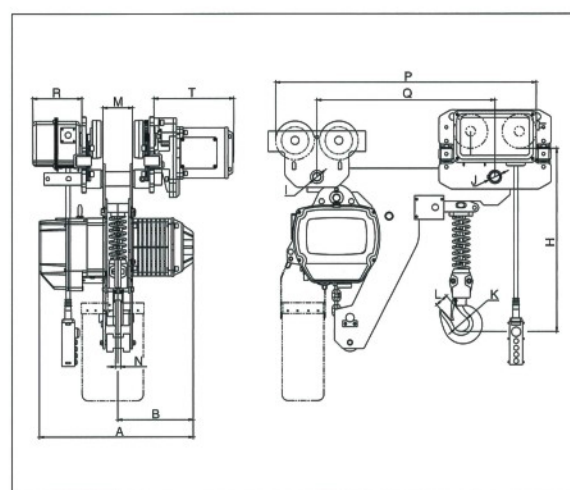

02-02

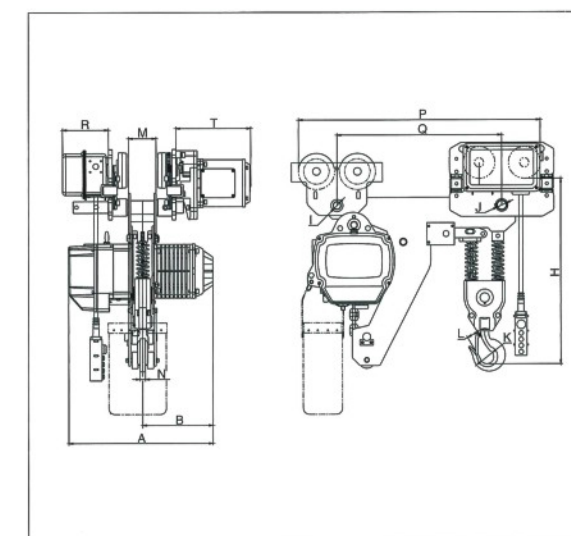

Super-low lifting

● Technical Parameters

Type	Capacity (Ton)	Lifting Height (m)	Lifting Speed (m/min)	Lifting motor					Operating motor					I-Beam (mm)	
				Power (kw)	Rotation Speed(r/min)	Phases	Voltage(V)	Frequency (Hz/s)	Power (kw)	Rotation Speed(r/min)	Operating speed(m/min)	Phases	Voltage(V)		Frequency (Hz/s)
HHBBL0.5-01S	0.5	3/9	7.2	1.1	1440	3	220-440	50/60	0.4	1440	10/20	3	220-440	50/60	100-180
HHBBL01-01S	1	3/9	6.8	1.5	1440	3	220-440	50/60	0.4	1440	10/20	3	220-440	50/60	100-160
HHBBL02-01S	2	3/9	6.6	3.0	1440	3	220-440	50/60	0.4	1440	10/20	3	220-440	50/60	100-160
HHBBL03-01S	3	3/9	5.6	3.0	1440	3	220-440	50/60	0.4	1440	10/20	3	220-440	50/60	120-180

● Size specification

Type	Capacity (Ton)	Unit(mm)													
		H	A	B	K	L	M	N	I	J	P	Q	R	T	Chain
HHBBL0.5-01S	0.5	350	460	230	Φ32	25	50	17	Φ31	Φ31	595	410	142	231	Φ6.3
HHBBL01-01S	1	480	520	260	Φ40	31	56	24	Φ31	Φ31	635	450	142	231	Φ7.1
HHBBL02-01S	2	570	620	310	Φ49	35	62	30	Φ36	Φ36	727	512	142	231	Φ10.0
HHBBL03-01S	3	640	620	310	Φ59	42	74	35	Φ43	Φ43	779	530	142	231	Φ11.2

Super-low lifting

● Technical Parameters

Type	Capacity (Ton)	Lifting Height (m)	Lifting Speed (m/min)	Lifting motor					Operating motor					I-Beam (mm)	
				Power (kw)	Rotation Speed(r/min)	Phases	Voltage(V)	Frequency (Hz/s)	Power (kw)	Rotation Speed(r/min)	Operating speed(m/min)	Phases	Voltage(V)		Frequency (Hz/s)
HHBBL01-02S	1	3/9	3.6	1.1	1440	3	220-440	50/60	0.4	1440	10/20	3	220-440	50/60	100-160
HHBBL02-02S	2	3/9	3.4	1.5	1440	3	220-440	50/60	0.4	1440	10/20	3	220-440	50/60	120-160
HHBBL03-02S	3	3/9	3.3	3.0	1440	3	220-440	50/60	0.4	1440	10/20	3	220-440	50/60	120-180
HHBBL05-02S	5	3/9	2.8	3.0	1440	3	220-440	50/60	0.75	1440	10/20	3	220-440	50/60	120-180

● Size specification

Type	Capacity (Ton)	Unit(mm)													
		H	A	B	K	L	M	N	I	J	P	Q	R	T	Chain
HHBBL01-02S	1	410	460	230	Φ40	31	50	24	Φ31	Φ31	595	410	142	231	Φ6.3
HHBBL02-02S	2	535	520	260	Φ49	35	56	30	Φ31	Φ31	670	450	142	231	Φ7.1
HHBBL03-02S	3	685	620	310	Φ59	42	62	35	Φ43	Φ43	750	505	142	231	Φ10.0
HHBBL05-02S	5	740	620	310	Φ60	45	77	43	Φ43	Φ54	820	530	142	231	Φ11.2



7.5-03

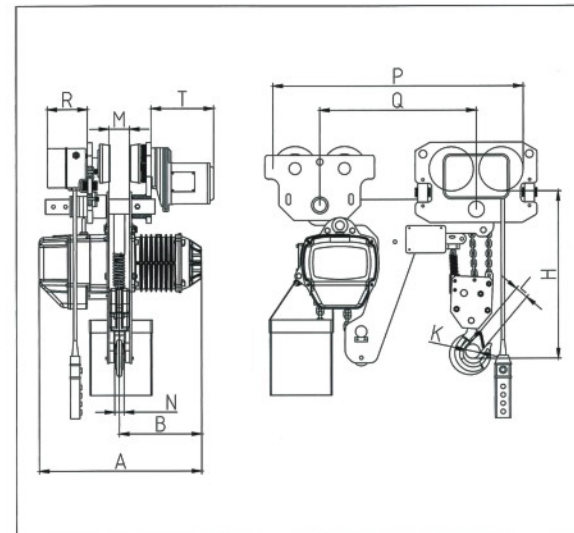

10-04

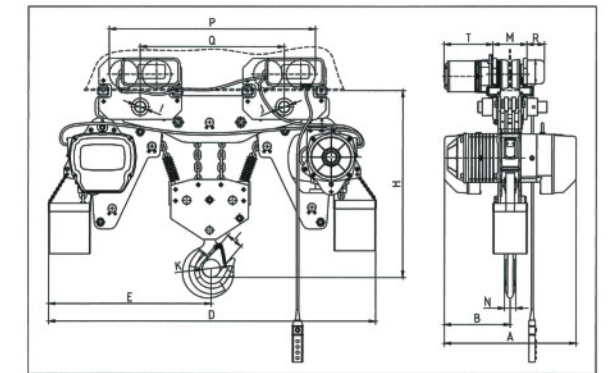

Super-low lifting

● Technical Parameters

Type	Capacity (Ton)	Lifting Height (m)	Lifting Speed (m/min)	Lifting motor					Operating motor					I-Beam (mm)	
				Power (kw)	Rotation Speed(r/min)	Phases	Voltage(V)	Frequency (Hz/s)	Power (kw)	Rotation Speed(r/min)	Operating speed(m/min)	Phases	Voltage(V)		Frequency (Hz/s)
HHBBL7.5-03S	7.5	3/9	1.8	3.0	1440	3	220-440	50/60	0.75	1440	10/20	3	220-440	50/60	120-180

● Size specification

Type	Capacity (Ton)	Unit(mm)													
		H	A	B	K	L	M	N	I	J	P	Q	R	T	Chain
HHBBL7.5-03S	7.5	900	620	310	Φ90	65	77	50	Φ43	Φ54	1024	740	142	231	Φ11.2

Super-low lifting

● Technical Parameters

Type	Capacity (Ton)	Lifting Height (m)	Lifting Speed (m/min)	Lifting motor					Operating motor					I-Beam (mm)	
				Power (kw)	Rotation Speed(r/min)	Phases	Voltage(V)	Frequency (Hz/s)	Power (kw)	Rotation Spedd(r/min)	Operating speed(m/min)	Phases	Voltage(V)		Frequency (Hz/s)
HHBBL10-04S	10	3/9	2.8	3.0x2	1440	3	220-440	50/60	0.75	1440	10/20	3	220-440	50/60	120-180

● Size specification

Type	Capacity (Ton)	Unit(mm)															
		H	A	B	D	E	I	J	K	L	M	Q	P	T	R	N	Chain
HHBBL10-04S	10	880	630	315	1640	820	Φ54	Φ54	Φ90	65	77	613	926	231	142	50	Φ11.2

联体车轮 Crane Wheel



20-08

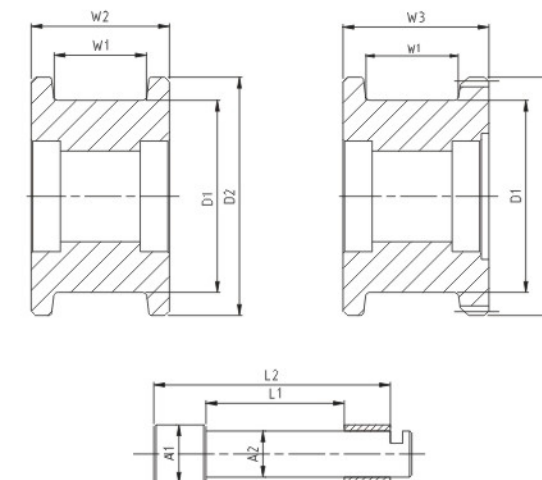
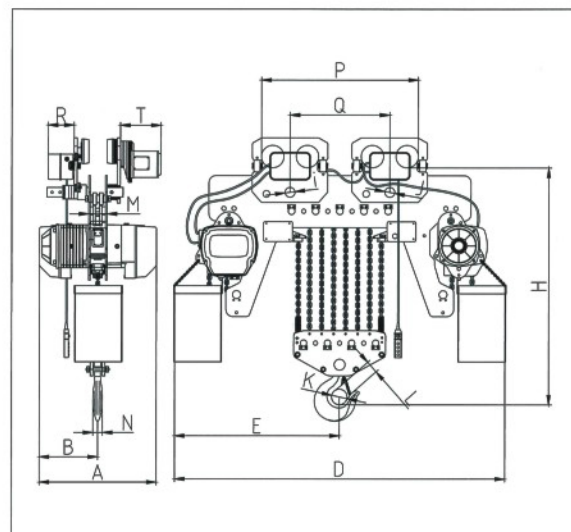

特性简介 (MAIN FEATURES)

联体车轮采用45#钢锻制，表面热处理硬度HRC45~52，采用HRB轴承，可满足各种行走机构需求，也可根据要求定制非标型号车轮。

Made of 45# steel forging, heat treatment hardness of HRC45~52 on surface, it use of HRB bearings, can meet the needs of various walking mechanism, can also be customized according to the requirements of non standard model wheel.

Super-low lifting

● Technical Parameters

Type	Capacity (Ton)	Lifting Height (m)	Lifting Speed (m/min)	Lifting motor					Operating motor					I-Beam (mm)	
				Power (kw)	Rotation Speed(r/min)	Phases	Voltage(V)	Frequency (Hz/s)	Power (kw)	Rotation Speed(r/min)	Operating speed(m/min)	Phases	Voltage(V)		Frequency (Hz/s)
HHBBL20-08S	20	3/9	1.4	3.0x2	1440	3	220-440	50/60	0.75x2	1440	10/20	3	220-440	50/60	130-180

● Size specification

Type	Capacity (Ton)	Unit(mm)															
		H	A	B	D	E	I	J	K	L	M	Q	P	T	R	N	Chain
HHBBL20-08S	20	1080	630	315	1905	975	Φ70	Φ70	Φ110	80	80	600	960	231	142	85	Φ11.2

车轮型号 Model	最大轮压 Load (kN)	D1(mm)	D2(mm)	W1(mm)	W2(mm)	W3(mm)	L1(mm)	L2(mm)	A1(mm)	A2(mm)	齿轮参数 Gear modulus
W100	50	100	130	60	90	95	90	154	38	30	M3
W150	100	150	100	65	95	100	83	154	58	50	M3
W200	180	200	230	70	100	105	88	204	58	50	M4
W250	250	250	280	80	110	130	96	204	78	70	M4
W315	350	315	355	90	120	130	120	204	78	70	M5

Electric Trolley

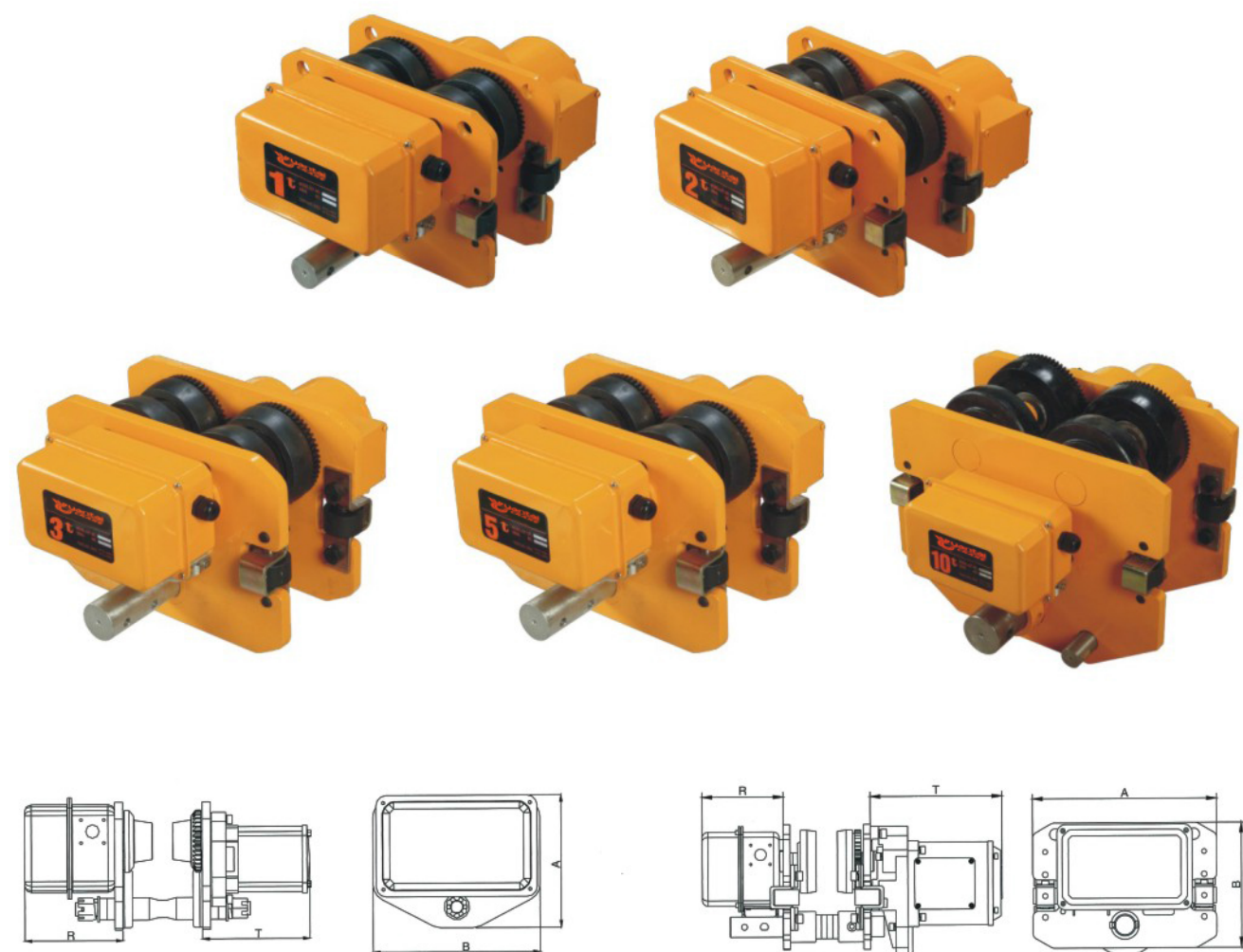

● Size specification

Type	Capacity (Ton)	Unit(mm)				Speed 50Hz(m/min)	Motor (Kw)	Minimum radius of turn	I-Beam (mm)
		A	B	R	T				
ET-0.5	0.5	196	248	142	159	14	0.2	0.8	70-130
ET-01	1	315	212	142	231	10 or 20	0.4	0.8	80-160
ET-02	2	325	220	142	231	10 or 20	0.4	0.8	82-178
ET-03	3	340	250	142	231	10 or 20	0.4	1.0	100-180
ET-05	5	400	291	142	231	10 or 20	0.75	1.8	110-180
ET-7.5	7.5	400	291	142	231	10 or 20	0.75	1.8	100-178
ET-10	10	500	370	142	231	10 or 20	0.75	2.5	150-220

Manual Trolley

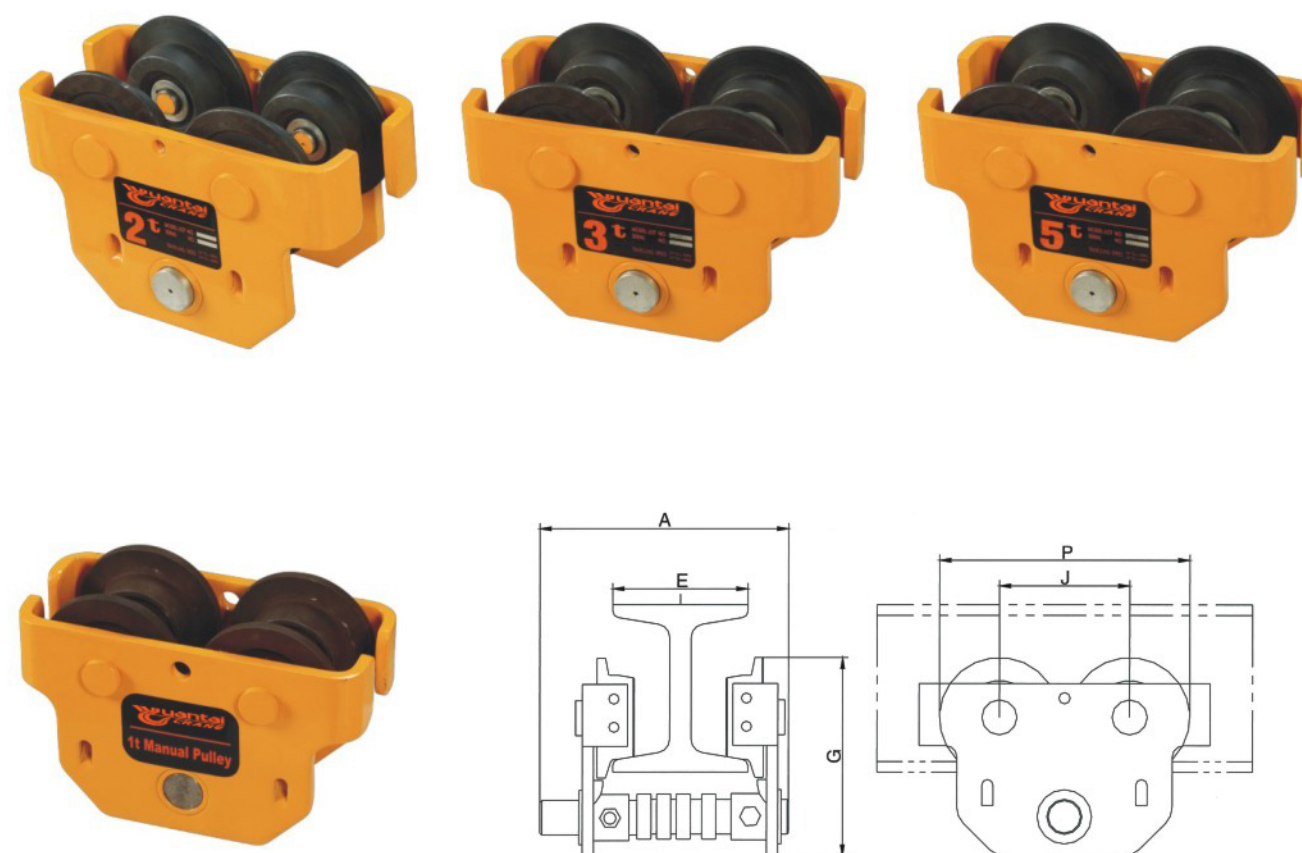

● Size specification

Type	Capacity (Ton)	Unit(mm)					Minimum radius of turn
		A	G	J	E	P	
MT-0.5	0.5	200	130	91	50-102	163	0.6
MT-01	1	200	170	115	50-102	221	1.3
MT-02	2	218	205	138	68-130	265	1.3
MT-03	3	275	236	157	82-153	305	1.7
MT-05	5	275	280	178	82-153	332	2.3