



Innovation Professional Safety Economic

创新 / 专业 / 安全 / 经济



www.ytcrane.com

Henan Yuantai Crane Machinery Import&Export Co., Ltd.

Tel: 86-371-65760776 Fax: 86-371-65760775 Skype: ytcranes

Email: yuntai@ytcrane.com Web: www.ytcrane.com

Address: Henghua Business Building 712, Garden Road, Zhengzhou, Henan, China.



YUANTAI CRANE



公司简介

Company Profile



作为专业的电动葫芦制造商和起重机设备和服务的供应商，远泰起重机勇于创新，追求技术进步，精益求精，致力于为客户提供专业的更安全、更经济的起重机解决方案，并依托我们的技术中心和研发中心，为客户提供个性化的物流搬运解决方案，满足客户对物流搬运和输送、工艺布局和提升效率的要求。公司提供全面的起重机产品和服务，产品覆盖各种工业起重机、钢丝绳电动葫芦、环链电动葫芦等起重机产品和优质的起重机服务。

远泰起重机秉承客户第一、技术领先、性能最佳、安全可靠、为客户持续创造价值的理念，为客户提供全系列的起重机产品和服务。我们将基于丰富的行业经验和优秀的R&D中心，与各学术机构和行业专家密切的合作，推动起重机及物流搬运行业的技术发展，能为客户提供更好的产品和服务。我们“模块化设计、提升物流效率”为客户创造价值的设计和提供方案的理念，充分考虑产品的技术领先性、产品的易于安装和维护性、客户使用的舒适简便性，致力于为客户降低成本、提升效率，为客户长期创造价值。

As a professional manufacturer of electric hoists and supplier of lifting equipments and service, Yuantai cranes is devoted to innovation, technological progress, excellence and providing customers with professional, safer, more economical crane solutions. Relying on our technology center and R&D center, we provide customers with customized material handling solutions to meet customers' requirements for logistics handling and conveying, process layout, and efficiency. The company offers comprehensive lifting products and service, covering a variety of industrial cranes, wire rope hoists, electric chain hoists and crane service.

Adhering to the concept of "customer first, leading technology, best performance, safety and reliability, constant creation of value for customers", Yuantai cranes provides customers with a full range of crane products and services. We will more actively rely on our technology and R & D center and close cooperation with various academic institutions and industry experts, to promote technical progress for cranes and material handling and to provide customers with better products and services. Our "modular design, improved logistics efficiency" and solutions give full consideration of product's technology leadership, easy installation and maintenance, simple and comfort use, are committed to costs reduction, efficiency improvement and long-term value creation for customers.



远泰起重机的产品在全球被广泛应用于汽车工业、风电行业、造船业、机械加工行业、钢铁、航空、造纸行业等。远泰起重机顺应时代发展，以严谨的工作作风、专业的设计团队，严格的质量控制、精益求精的制造为用户提供更加安全可靠的产品。

远泰起重机积极推行现代先进技术在电动葫芦和起重机上的应用，如变频控制、制动能量反馈、安全监控系统等。新技术的应用让起重机控制智能化，同时也提升了起重设备安全操作性能，便于客户对起重机的维护和起重机运行状态的监控，有效降低了设备运行的能耗。



Yuantai cranes' products are widely used in the automotive, wind power industry, shipbuilding, machinery processing, steel, aviation and paper industries. Yuantai cranes, following the development of the times, provides users with more safe and reliable products through its precise work style, professional design team, strict quality control and excelsior manufacturing.

Yuantai cranes vigorously promotes application of modern advanced technology in electric hoist and crane, such as variable frequency control, braking energy feedback, security monitoring systems. Application of new technologies leads to the intelligent control of cranes, improvement of safe operation of lifting equipment, facilitation crane maintenance and operation monitoring by customers, effectively reducing the energy consumption of device operation.





远泰起重机的中国工厂国家级经济开发区---苏州市吴江经济开发区，公司集研发、生产、销售为一体，向全球市场提供各类起重设备。我们将以客户为中心，不断追求工业进步，为客户提供安全可靠、性能优良和运行高效的满足各种工况的起重机产品。

Yuantai cranes established the factory in Wujiang Economic Development Zone in Suzhou. Combining R&D, production and sales, the company supplies a range of lifting equipment to the global market. Led by customer orientation and constant pursuit of industrial progress, we will provide customers with safe, reliable, excellent and efficient lifting products that can accommodate various working conditions.



Origin in Europe and Service for China

目录 Contents

NWH系列钢丝绳葫芦
NWH series wire rope hoist

NCH系列环链葫芦
NCH series chain hoist

工业起重机
Industrial crane

零配件及服务
Parts and service

典型客户
Customers



源于欧洲 服务中国

产品优势 Product advantages



1 效率最高，最大限度利用空间

Highest efficiency, maximized use of space

领先的技术设计保证了产品最优化的极限尺寸，在保证性能高效下结构最紧凑，为在同样的厂房和工作区域内，应用NWH钢丝绳电动葫芦或者NCH环链电动葫芦能够覆盖更大的范围，减少盲区。如果在厂房设计阶段就使用远泰的产品系列参数进行设计，可以大大降低对厂房高度的要求，为客户节省投资、增效降本。

Leading technical design guarantees the optimal product size limits. Under preconditions of performance and efficiency, the most compact structure makes the application of NWH electric wire hoist or NCH electric chain hoist cover a larger area in the same plant and work area, reducing dead spots. If the plant is designed according to Yuantai cranes design parameters, the requirements for the plant height will be greatly lowered, saving investment, improving efficiency and reducing cost for the customers.

2 精确定位，运行高效，提升物流效率

Precise positioning, efficient operation, enhanced logistics efficiency

强劲高品质的起升驱动确保运行的安全平稳和高效，紧凑的结构设计确保吊钩的偏移尺寸最小，起升提供双速（变频可选）、大车小车均为变频的标准配置，确保了起重机的运行、车间物流效率的提升，确保客户的各项工作计划如期执行。

Strong high-quality lifting driver is designed to ensure a smooth, safe and efficient operation. The compact design can ensure the smallest offset of hooks. The standard configurations of dual-speed (frequency optional) lifting and variable frequency trolleys and carts make sure of efficient operation of the crane, improvement of shop logistics efficiency and work progress on schedule for the customer.

3 安全可靠，运行监控，便于维修

Safety and reliability, operation monitoring, easy maintenance

远泰的专利技术NOVOSTAR有多种保护功能装置确保起重机运行安全和可靠，其运行监控单元可以对电动葫芦运行情况、电机运行状态和安全工作周期的计算等进行详细的记录，并提供警告。所有的记录可以为维修提供数据，了解问题的根源，让起重机的维护保养计划更及时和合理。

NOVOSTAR, Yuantai cranes' patented technology, provides a variety of protection devices to ensure safe and reliable operation of crane. The monitoring unit can record in detail the operation of hoist, motor running and calculation of safe working cycle and provide a warning. All these records are able to provide data for maintenance, help to understand the source of the problem, so that the crane maintenance program can be made more timely and reasonable.

NWH钢丝绳电动葫芦 NWH wire rope hoist

远泰NWH系列钢丝绳葫芦，采用C型设计，结构紧凑，运行平稳，定位精确。德国原装进口的高效起升和运行机构确保每一台电动葫芦性能优良，安全可靠。变频控制、制动能量反馈及安全监控系统等新技术的应用使远泰钢丝绳电动葫芦始终处于行业的前列。

Yuantai cranes' NWH Series wire rope hoists are designed as C-type with compact structure, smooth operation and precise positioning. The high-efficient lifting motor imported from Germany can ensure the performance, safety and reliability of every hoist. Application of frequency control, braking energy feedback and security monitoring systems and other new technologies makes Yuantai cranes wire rope hoist among the top of the industry all the time.

凭借远泰起重机的领先技术和丰富的行业经验，从客户的需求出发，从应用出发，基于模块化设计的理念，拥有多项专利和发明的钢丝绳电动葫芦产品确保质量可靠，性能优良。应用我们的电动葫芦能够为您提供更好的物流解决方案，保证设备运行的可靠性和安全性。

With leading technology and rich industry experience, from the point of customer's needs and application and based on a modular design, the wire rope hoists with many patents and inventions can ensure reliable quality and excellent performance. Our hoists will provide you with better logistics solutions and equipment of reliable and safe operation.



4 模块化设计，维护成本低，完善的零配件服务

Modular design, low maintenance cost, perfect spare parts service

模块化设计的理念一直贯穿于整个产品的设计，保证了部件的标准化和互换性，大大提高产品质量并降低了产品的维护成本。我们公司所有的产品系列都有完整的零配件库存，公司拥有专业的服务队伍，确保为客户及时提供售后服务，解决客户购买设备之后的后顾之忧。

Modular design concept has been incorporated into the entire product design to ensure standardization and interchangeability of components, considerably improving product quality and reducing maintenance cost. We have complete inventories of spare parts for all products. The professional service team of the company ensures timely service and spares customers from worry after purchase of equipment.



◀ NWH单梁钢丝绳电动葫芦
NWH single girder wire rope hoist



◀ NWH双梁钢丝绳电动葫芦
NWH double girder wire rope hoist



吊钩组 Hook block

DIN标准吊钩，带安全扣及钢丝绳护套
DIN standard hooks with belt buckle and wire ropes sheath

电控箱 Electric cabinet

布线合理，检修方便，多种控制保护，操作安全
Reasonable design, easy maintenance, a variety of security devices to ensure safe operation and running of equipment



运行机构 Travelling system

减速箱、电机和制动器三合一设计，结构紧凑，运行平稳，效率高，冲击力小
Integrated design of gearbox, motor and brake, compact structure, stable operation, High efficiency, small impact



安全监控器 Safety monitor

Novostar智能化监控，安全实用，人机友好界面，操作简单
Novostar intelligent monitoring system, safe and practical, human-friendly interface, simple operation



起升马达 Lifting motor

铝合金壳体，高性能起升电机带盘式制动器，免维护设计
Aluminum shell, high-performance lifting motor with disc brakes, free maintenance design



接插件 Connectors

航空接插件，检验安全方便，防护等级高，IP55以上
Connectors for aviation, safe and easy maintenance, high protection of IP55



导绳器 Rope Guide

采用高韧性、抗断裂的工程塑料制成。重量轻、耐磨性好，减少对钢丝绳的磨损
Made of engineering plastic, light weight, excellent wear resistance, reducing tear and wear of wire



制动器 Brake

动作快，可靠性高，刹车间隙可自动调节，防尘设计，刹车片不含石棉
Fast, highly reliable, automatic adjustment during braking interval, dust-proof, maintenance-free, Asbestos-free brake pads



起升高度限制器 Height limiter switch

可自由调节的螺杆式起升高度限位器精度高，调节范围广。多触点的配置可有效实现上升和下降时的快、慢速的切换及停止功能

Freely adjustable screw lifting height limiter with high precision and wide adjustment range. Multi-touch configuration can effectively achieve the switch between fast and slow speed during rise and fall and stop function



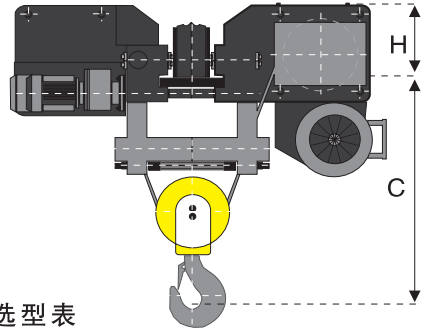

NWH单梁钢丝绳电动葫芦选型表
Selection table of NWH single girder wire rope hoist

额定载荷 S.W.L (Kg)	工作级别 FEM	工作级别 ISO	起升高度 Lifting height (m)	起升速度 Lifting speed (m/min)	运行速度 Travelling speed (m/min)	H 尺寸 Size H (mm)	C 尺寸 Size C (mm)
1000	4m	M7	6/9/12/18	0.8/5.0	5-20	232	500
1250	3m	M6	6/9/12/18	0.8/5.0	5-20	232	500
1600	3m	M6	6/9/12/18	0.8/5.0	5-20	232	500
1600	2m	M5	6/9/12/18	1.6/10	5-20	232	500
2000	2m	M5	6/9/12/18	0.8/5.0	5-20	232	500
2000	3m	M6	6/9/12/18	1.3/8.0	5-20	232	500
2500	3m	M6	6/9/12/18	0.8/5.0	5-20	232	500
2500	3m	M6	6/9/12/18	1.0/6.3	5-20	232	500
2500	2m	M5	6/9/12/18	1.3/8.0	5-20	232	500
3200	2m	M5	6/9/12/18	0.8/5.0	5-20	232	500
3200	2m	M5	6/9/12/18	1.0/6.3	5-20	232	500
3200	1Am	M4	6/9/12/18	1.6/10	5-20	254	590
5000	2m	M5	6/9/12/18	0.8/5.0	5-20	254	590
5000	3m	M6	6/9/12/17	1/6.3	5-20	321	740
5000	2m	M5	6/9/12/18	1.6/10	5-20	321	740
6300	1Am	M4	6/9/12/18	0.8/5.0	5-20	254	590
6300	4m	M7	6/9/12/18	0.8/5.0	5-20	321	740
6300	2m	M5	6/9/12/18	1.3/8.0	5-20	321	740
8000	3m	M6	6/9/12/18	0.8/5.0	5-20	321	740
10000	1Am	M4	6/9/12/18	1.0/6.3	5-20	321	740
10000	2m	M5	6/9/12/18	0.8/5.0	5-20	321	740
10000	3m	M6	6/9/12/18	0.66/4.0	5-20	321	740
12500	1Am	M4	6/9/12/18	0.8/5.0	5-20	321	740
12500	2m	M5	6/9/12/18	0.6/4.0	5-20	321	740
12500	1Am	M4	6/9/12/18	1.0/6.3	5-20	321	740
12500	3m	M3	6/9/12/19	0.6/4.0	5-20	411	850
16000	2m	M5	6/9/12/18	0.6/4.0	5-20	411	850
20000	1Am	M4	6/9/12/18	0.6/4.0	5-20	411	850

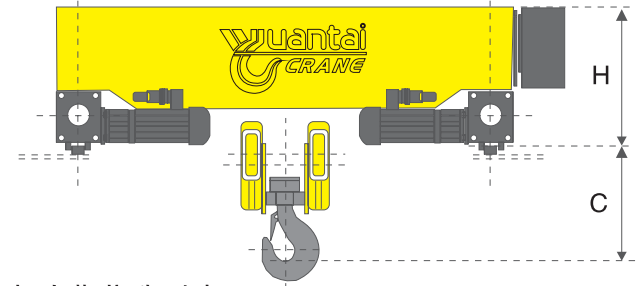

NWH双梁钢丝绳电动葫芦选型表
Selection table of NWH double girder wire rope hoist

额定载荷 S.W.L (Kg)	工作级别 FEM	工作级别 ISO	起升高度 Lifting height (m)	起升速度 Lifting speed (m/min)	运行速度 Travelling speed (m/min)	H 尺寸 Size H (mm)	C 尺寸 Size C (mm)
2000	3M	M6	6/9/12/18	0.8/5.0	5-20	463	350
3200	2M	M5	6/9/12/18	0.8/5.0	5-20	463	350
5000	2M	M5	6/9/12/18	0.8/5.0	5-20	463	350
6300	1AM	M4	6/9/12/18	0.8/5.0	5-20	463	350
8000	3M	M6	6/9/12/17	0.8/5.0	5-20	580	563
10000	1AM	M4	6/9/12/18	1.0/6.3	5-20	580	563
10000	2M	M5	6/9/12/18	0.8/5.0	5-20	580	563
10000	3M	M6	6/9/12/18	0.66/4.0	5-20	580	563
12500	1AM	M4	6/9/12/18	0.8/5.0	5-20	580	563
12500	1AM	M4	6/9/12/18	1.0/6.3	5-20	679	700
12500	2M	M5	6/9/12/18	0.6/4.0	5-20	679	700
16000	2M	M5	6/9/12/18	0.66/4.0	5-20	679	700
20000	1AM	M4	6/9/12/18	0.66/4.0	5-20	679	700
20000	2M	M5	6/9/12/18	0.53/3.4	5-20	679	700
20000	3M	M6	6/9/12/18	1.0/4.2	5-20	864	1000
25000	1AM	M4	6/9/12/18	0.53/3.4	5-20	864	1000
25000	3M	M6	6/9/12/18	0.8/3.3	5-20	864	1000
25000	2M	M5	6/9/12/18	1.0/4.2	5-20	864	1000
32000	2M	M5	6/9/12/18	0.8/3.3	5-20	864	1000
32000	2M	M5	6/9/12/18	0-4.9	5-20	1023	950
40000	1AM	M4	6/9/12/18	0-4.9	5-20	1023	950
50000	2M	M5	6/9/12/18	0-3.2	5-20	1023	950
50000	1AM	M4	6/9/12/18	0-4.1	5-20	1023	950
63000	1AM	M4	6/9/12/18	0-3.2	5-20	1023	950
63000	2M	M5	6/9/12/18	0-2.4	5-20	1023	1110
80000	1AM	M4	6/9/12/18	0-2.4	5-20	1023	1110

NCH环链电动葫芦

NCH Series Electric Chain Hoist

远泰NCH系列环链电动葫芦结构紧凑，性能可靠。环链葫芦严格按照FEM及DIN德国工业标准设计和制造，同时满足中国起重行业对特种设备的各标准的行业。模块化设计使我们的产品能灵活地组合成不同的起升吨位、起升速度和等级制度，满足客户的个性化需求。

主要驱动部件在设计安全使用周期内（10年）无需更换。标准化、人性化的设计在提升操作性能的同时大大降低了维护成本。

Yuantai cranes NCH Series electric chain hoist are featured by compact structure and reliable performance. Chain hoists are designed and manufactured in strict compliance with FEM and DIN, while meeting standards and industry codes for special equipment of Chinese crane industry. The modular design allows flexible product mix for different lifting tonnage, speed and working level to meet customers' individual needs.

The core driving components require no replacement within the safety utilization period (10 years). Standardized and personalized design improves operational performances while substantially reducing maintenance costs.

高使用性能
全内置式设计
即插即用
使用寿命等级增高
最高设计安全等级
经济适用，操作舒适
维修方便

High-performance
Design built-in
Plug and play
Long service life
Economical and ergonomic
Comfortable operation
Easy maintenance

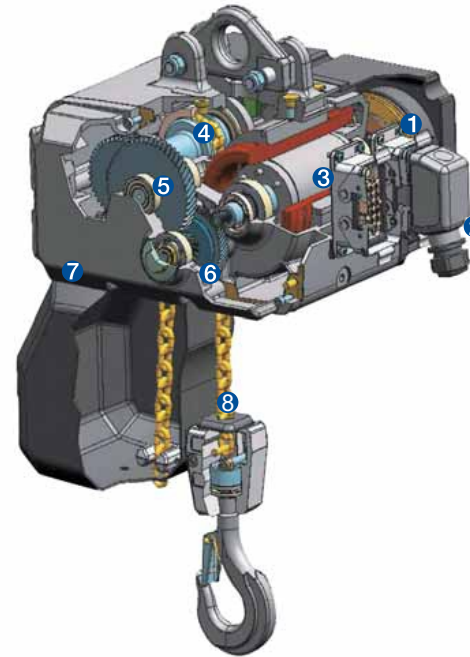

1 制动器 Brake

电磁盘式制动器集成在起升电机的端部，制动扭矩为电机额定扭矩的2倍
Electromagnetic disc brake is integrated at the end of lifting motor with the brake torque of 2 times of rating of motor.

2 电气接头 Electric connectors

电气接口均采用铝合金标准接插件，安全便捷。

Standard connectors of aluminum alloy are used as electrical interface, safe and convenient.

3 起升电机 Lifting motor

柱形转子双速电机，运行可靠，噪音低。标准绝缘等级为F级，防护等级IP55

Dual-speed motor with cylindrical rotor, reliable and low noise. Standard insulation class F, degrees of protection Ip55

4 导链器 Chain fairlead

导链器分为上下两部分，上导链器采用工程塑料，下导链器采用球墨铸铁

Chain fairlead is divided into two parts. The upper is made of engineering plastic and the lower of ductile iron.

5 安全离合器 Safety clutch

安全离合器集成在传动齿轮轴上，起到超载保护的作用，设定保持扭矩为安全载荷的1.4倍

Safety clutch is integrated in the driving gear shaft, serving as an overload protection. Set and keep the torque 1.4 times of safe load.

6 转动机构 Rotating mechanism

三级斜齿轮传动，每个齿轮都经过齿面硬化及研磨处理，运行平稳，噪音低

Three stage gear device with tooth surface of each gear hardened and ground, smooth running, low noise

7 机体外壳 Housing

铝合金壳体，重量轻，耐腐蚀且散热性能好

Aluminum alloy shell, light weight, corrosion resistance and excellent heat dissipation

8 链条 Chain

高强度渗碳链条，表面镀锌，安全耐用

High-strength carburized chain, zinc plated, safe and durable.

NCH环链电动葫芦外形尺寸

Dimensions of NCH Series Electric Chain Hoist

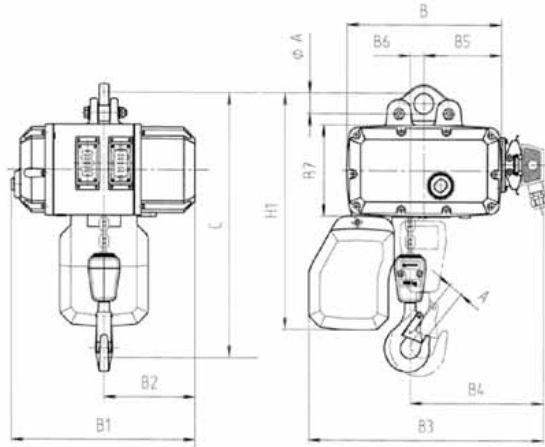

型号 Model	∅ A	A	B	B1	B2	B3	B5	B6	B7	C	H1	H2
NCH1单链 NCH1 single chain	36	22	280	327	165	425	140	25	160	367	415	515
NCH1双链 NCH1 double chains	36	32	280	327	156	425	140	0	160	463	415	515
NCH2单链 NCH2 single chain	36	22	280	327	165	425	140	25	160	367	415	515
NCH2单链 NCH2 single chain	36	26	280	327	165	425	140	25	160	400	415	515
NCH2双链 NCH2 double chains	36	32	280	327	165	425	140	0	160	463	415	515
NCH3单链 NCH3 single chain	52	32	310	375	196	502	166	24	180	480	512	662
NCH3双链 NCH3 double chains	52	38	310	375	196	502	166	0	180	570	512	662
NCH4双链 NCH4 double chains	80	56	450	500	220	550	190	45	210	820	850	980
NCH5双链 NCH5 double chains	90	60	450	500	220	550	190	0	210	820	850	980

环链电动葫芦机体的重量为：NCH1=30Kg;NCH2=33Kg;NCH3=54Kg;NCH4=85Kg;NCH5=95Kg
Weights of electric chain hoist: NCH1=30 Kg;NCH2=33Kg;NCH3=54Kg;NCH4=85Kg;NCH5=95Kg



NCH系列环链电动葫芦选型表

Selection table of NCH Series Electric Chain Hoist

额定载荷 S.W.L (Kg)	工作级别 FEM	工作级别 ISO	型号 Hoist type	最大起升高度 Max Lifting height (M)	起升速度 Lifting speed (M/min)	链条数 NO.of falls
250	1AM	M4	NCH1025108F	21	2.00/8.00	1
250	3M	M6	NCH2025108F	21	2.00/8.00	1
320	3M	M6	NCH2032108F	21	2.00/8.00	1
400	2M	M5	NCH2024108F	21	2.00/8.00	1
500	1AM	M4	NCH1050104F	10	1.00/4.00	2
500	3M	M6	NCH2050204F	10	1.00/4.00	2
500	1AM	M4	NCH2050108F	21	2.00/8.00	1
500	3M	M6	NCH3050110F	21	2.50/10.00	1
630	3M	M6	NCH2063204F	10	1.00/4.00	2
630	2M	M5	NCH3063110F	20	2.50/10.00	1
800	2M	M5	NCH2080204F	10	1.00/4.00	2
800	1AM	M4	NCH3080110F	20	2.50/10.00	1
1000	1AM	M4	NCH2100204F	10	1.00/4.00	2
1000	1BM	M3	NCH3100110F	20	2.50/10.00	1
1000	3M	M6	NCH3100205F	10	1.25/5.00	2
1250	3M	M6	NCH3125205F	10	1.25/5.00	2
1600	2M	M5	NCH3160205F	10	1.25/5.00	2
2000	1AM	M4	NCH3200205F	10	1.25/5.00	2
3000	1AM	M4	NCH4300206F	10	1.50/6.00	2
3000	1AM	M4	NCH4300204F	10	1.00/4.00	2
4000	1AM	M4	NCH4400204F	10	1.00/4.00	2
5000	1AM	M4	NCH5500204F	10	1.00/4.00	2

NCH系列环链电动葫芦标准供货范围包括：

Standard scope of supply of NCH series electric chain hoists includes:

1、双速起升的葫芦机体，银灰色面漆；2、可拆卸的上吊耳；3、380V/48V/50Hz起升电控系统；4、带快速接头的控制用手电门；5、上下起升限位开关；6、黑色塑料链盒；7、吊钩及链条（3米起升高度）

1, dual-speed hoist body, silver-gray finish; 2 removable lifting lug; 3, 380 V/48V/50Hz lifting electronic control system; 4, manual electric switch for control of quick connector; 5 limit switch for rise and fall; 6, black chain box; 7, hook and chain (3 m lifting height)

不同应用场合，多种选项供您选择

A variety of options available for different applications.

1、220V直接控制；2、手动或电动运行小车 3、无线遥控器；4、超大链盒（大起升高度）

1, 220V direct control; 2, manual or electric-operated trolley; 3, wireless remote controller; 4, extra-large chain box (higher lifting height)



风力NCH-W环链电动葫芦
NCH-W Series Electric Chain Hoist

起重量: 250-1000Kg
Load: 250-1000Kg



风力NCH-W环链电动葫芦 ■ NCH-W Series Electric Chain Hoist



- 起升高度可达120米
- 双速起升控制
- 安全可靠
- 节能环保
- 环境友好性产品

- Lifting height up to 120 m
- Dual-speed lifting control
- Safe and reliable performance
- Environmental conservation
- Environmentally friendly products

远泰NCH系列环链电动葫芦与柔性梁系统及悬臂吊结合在一起将更能发挥其轻便灵活的优势，充分实现立体化的物料输送解决方案。

Yuantai cranes' NCH Series electric chain hoist in combination of light flexible beam crane and swing-jib crane will better exert its advantages of lightweight and flexibility, fully realize the solutions to three-dimensional material handling and meet customer requirements for process layout, greatly improving production efficiency.





工业起重机 Industrial crane

远泰起重机为客户提供全面工业起重机设备和各种类型的起升机构，产品系列全，应用范围广。从简单的工位解决方案到专业起重机定制、从车间多点支撑起重机到高度自动化的起重机，我们将根据客户的需求和设想，为您提供全套的物料搬运解决方案。

远泰起重机拥有一流的设计人员和多年从事起重设备制造经验的工程师，我们为全球知名企业提供为客户生产效率的改进提供更多的物流方案的技术咨询和设备，我们与客户共同携手，帮助客户解决生产物流方面的问题，为客户提供安全可靠的产品，获得了众多客户的信任。全球领先的起重机设计、灵活的起重机产品组合、现代化加工工艺和严格的质量控制让我们产品在同行业中遥遥领先。

Yuantai cranes provides customers with a full range of lifting equipment and various types of lifting mechanisms for wide application. From simple station solution to professional customization, from multi-point supported to highly automated cranes, we will supply complete range of material handling solutions based on customer needs and ideas.

Yuantai cranes has first-class designers and engineers engaged in the lifting equipment manufacturing for many years, who provide more technical advices on logistics solutions and equipment to world-renowned enterprises to improve production efficiency. We work together with our customers to help solve the problems in logistics, provide safe and reliable products, thus winning their trust. The world's leading crane design, flexible product mix, modern processing technology and strict quality control contribute to our commanding leading in the industry ahead.



电动单梁悬挂起重机 Electric single girder suspension crane

最大起重量: 20t
Maximum load: 20t

悬挂式起重机可以直接安装在现有厂房的屋顶钢结构的工字钢或者H型钢上，不需安装承载梁和起重轨道，客户可以降低投资成本，并完全使用整跨厂房面积，特别是通过使用侧端悬臂，可使小车的行驶超出起重机跨距，使得客户能够更有效的利用厂房面积。

Electric single girder suspension cranes can be mounted directly on the roof steel structure or H steel beam of the existing plant, no need for bearing beams and crane rail tracks, reducing customers' investment cost. In addition, the whole inter-plant area can be fully used, and particularly the side-cantilever can make the trolley travel beyond the crane's span, allowing for more efficient use of plant area.





电动单梁起重机

Electric single girder crane

最大起重量:20t
Maximum load: 20t

单梁桥式起重机配有各种尺寸的低净空钢丝绳电动葫芦和环链电动葫芦，满足不同客户的需求，提供生产效率。利用计算机优化设计主梁使单梁起重机在低自重下具有最强的稳定性，制动平稳定位精确，是用于轻载和超短跨距的最佳方案。

Electric single girder cranes can be equipped with a variety of wire rope hoists and chain hoists to meet different needs, improving productivity. The advanced optimization of structural design of the main beam gives the electric single-girder crane the highest stability under low dead weight and stable and accurate positioning braking, ideal for light load and short span application.

双梁桥式起重机

Double beam bridge crane

最大起重量:200t
Maximum load :200t

远泰起重机的双梁桥式起重机具有自重轻，净空低、轮压小等特点，大大节约厂房投资；起重机配置大小车变频控制，使运行可靠安全稳定；其结构设计合理，保证起重机良好的运行状态并且把磨损降到最低，减少设备在使用过程中的维护量。由于吊钩可以上升到两根主梁之间，故使其起升高度大幅提高。作为可选项，还可以加装维修平台和小车平台，这不仅便于起重机的维护保养，还能使维修人员迅速安全的到达厂房里的其他设施，如照明设备、暖气或动力管线等。

Yuantai cranes double girder overhead crane is featured by light weight, low headroom and wheel pressure, significantly saving the investment on plant. The variable frequency control of trolleys and carts makes operation reliable, safe and stable. The reasonable structure design ensures good running and minimizes wear and maintenance of equipment during service. Since the hook rises to between the two main beams, its lifting height can be substantially increased. As an option, you can also install a service platform and trolley platform, which not only facilitate the maintenance of cranes, but also help maintenance personnel to quickly access other facilities in the plant, such as lighting, heating or power lines, etc.



门式起重机 Gantry crane

最大起重量:100t
Maximum load: 100t

门式起重机分为全门式和半门式，采用欧式优化设计，具有自重轻，轮压小，尺寸小等特点，充分利用厂房的空间和场地，无需改变厂房结构。源于欧洲驱动性能和变频调速等核心技术，为客户提供安全可靠的物料输送设备，满足客户对于物流搬运的需求。

Gantry crane includes full-portal and semi-portal types with European optimized design. It is featured by light weight, low wheel pressure and small size. It makes full use of plant area and space without changing the plant structure. Originated in European core technologies such as driving performance and variable frequency control, it provides customers with safe and reliable equipment for material conveying to meet customer demand for logistic.



悬臂起重机 Jib crane

最大起重量:10t
Maximum load:10t



远泰起重机立柱式和墙壁式旋臂吊都可以选配钢丝绳电动葫芦或者环链电动葫芦，能帮助您缩短生产准备和非生产性工作时间。旋臂吊规格多、品种全，无论您对起升重量、旋转角度，臂长和功能有什么样的要求，我们都能为您提供最佳的解决方案。所有的规格都具有自重轻，旋臂长，起重重量大的优点。

Yuantai cranes vertical and wall-mounted jib cranes can be equipped with electric wire rope hoist or chain hoist, help you shorten production preparation and non-productive work time. Thanks to a number of specifications and types, we can provide the best solution regardless of your requirements for lifting weight, rotation angle, beam length and function. The swing jib cranes of all specifications are featured by light weight, long beam length and large lifting weight.





柔性梁轻型起重机 Light flexible beam crane

最大起重量:2t
Maximum load: 2t

远泰起重机柔性梁系统有三种不同型材制成的柔性梁轨道，可为各种应用提供解决方案，几乎可以囊括所有的需求。

柔性梁轻型起重机自重轻，对建筑的承载能力低要求。标准模块化设计的部件可以满足客户车间的工艺布局和物流需求的个性化方案，使得组合和安装非常简单、方便。与NCH系列环链电动葫芦结合使用，可以平稳、准确地完成货物操作，最大限度地缩减了运作时间和人员需求。

Yuantai cranes flexible beam system has three flexible beam tracks available made of different profiles, providing solutions for a variety of applications, meeting almost all needs.

Light flexible beam crane has low dead weight, resulting in low requirements for building's load capacity. Standard modular components are designed to meet the customer's process plant layout and logistics needs of individual programs, making the combination, and installation is very simple and convenient. And NCH series electric chain hoist is combined with a smooth, accurate completion of cargo operations minimizes operation time and personnel requirements.



零配件及服务 ■ Parts and service

远泰起重机在苏州工厂设有独立的备件中心，在全国各地设立多个服务网点，确保全系列备件快速供货。远泰起重机备件品种齐全，从您购买起重机的时刻开始，也就是您省心放心使用的开始，我们会确保您的设备一直处于最佳运行状态。

Yuantai cranes has set up a separate center of spare parts in Suzhou factory with a number of service outlets across the country to ensure quick delivery of all range of spare parts. With 'Yuantai cranes' s full range of spare parts, the moment you purchase a NOVO crane is the start for your free and easy use. We will ensure that your equipment will be running at its best all the way.



遥控器
remote controller



起升电机
lifting motor



电路控制板
circuit control panel



安全监控装置
NOVOSTAR



手电门
Push Button



钢丝绳
wire rope

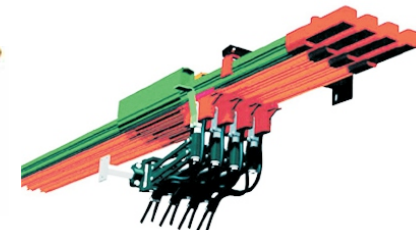

安全滑触线
Power feeding line



典型客户 ■ Customers



全方位的售后技术解决方案:

- 设备安装
- 备品备件供应
- 部件维修
- 维护保养服务
- 应急维修服务
- 设备改造服务
- 提供专业的培训



After-sales technical solutions:

- Cranes Installation
- Spare Parts
- Parts Repair
- Maintenance Service
- 24 Hours Stand-by Service
- Cranes Modification
- Training

我们有专业的售后服务人员和技术团队，为您提供有保障的售后服务，保证起重机在良好的状态下帮助客户专注核心业务
We have professional after-sales service team and professional technical team, ensuring our customers can concentrate on their own business, leaving the operations of the cranes to our care.

远泰起重机产品的性能和质量是我们取得成功和提高信誉的基石，并得到广大中国客户的认可。
Performance and quality of Yuantai cranes products is the cornerstone of our current success.
We will continue to provide Chinese customers with quality products and services.



期待您的加入