



# NR 型 钢丝绳电动葫芦

## NR TYPE

WIRE ROPE  
ELECTRIC HOIST



Henan Yuantai Crane Machinery Import & Export Co., Ltd.

ADD: No. 1, Weier Road, Henan (Changyuan) Crane Industry Park, China.

Tel: 0086-371-65760776

Email: [dongqi@dqcranes.com](mailto:dongqi@dqcranes.com)

Web: [www.dqcranes.com](http://www.dqcranes.com)

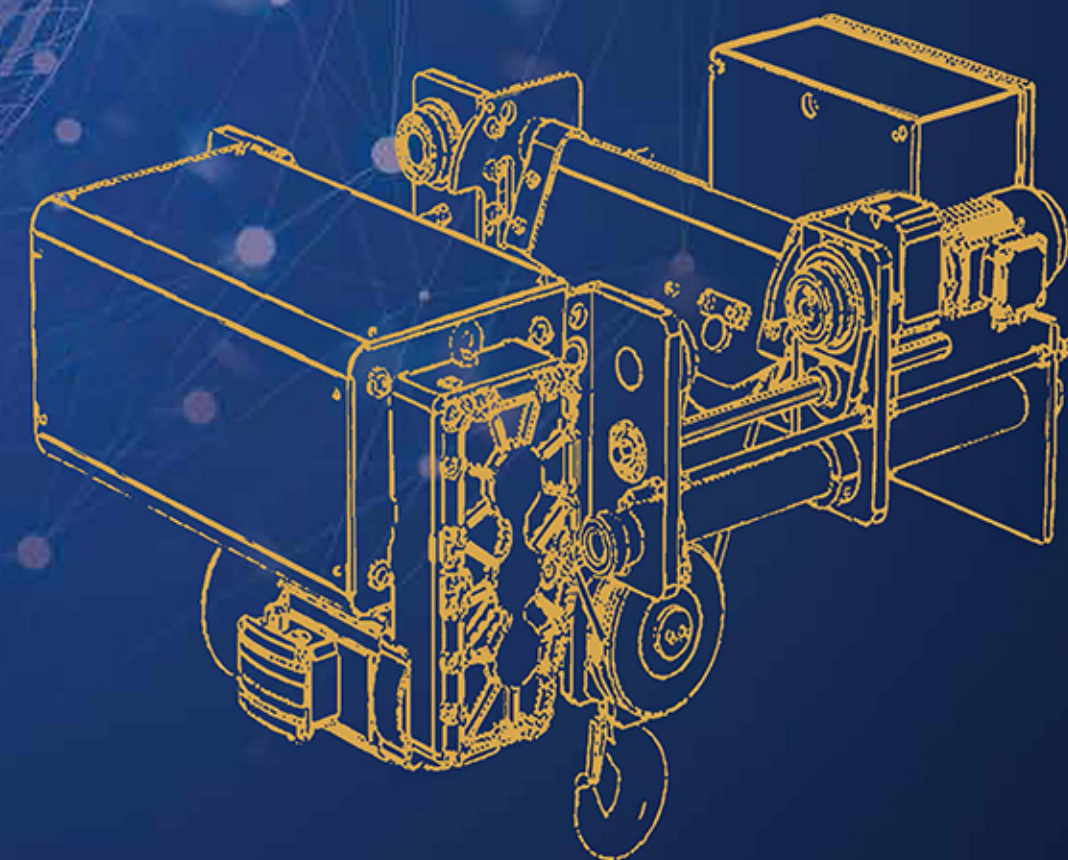



NR 型钢钢丝绳电动葫芦，有以下四种结构设计可供用户选择：

NR Wire Rope Electric Hoist has four structural designs for users to choose from:

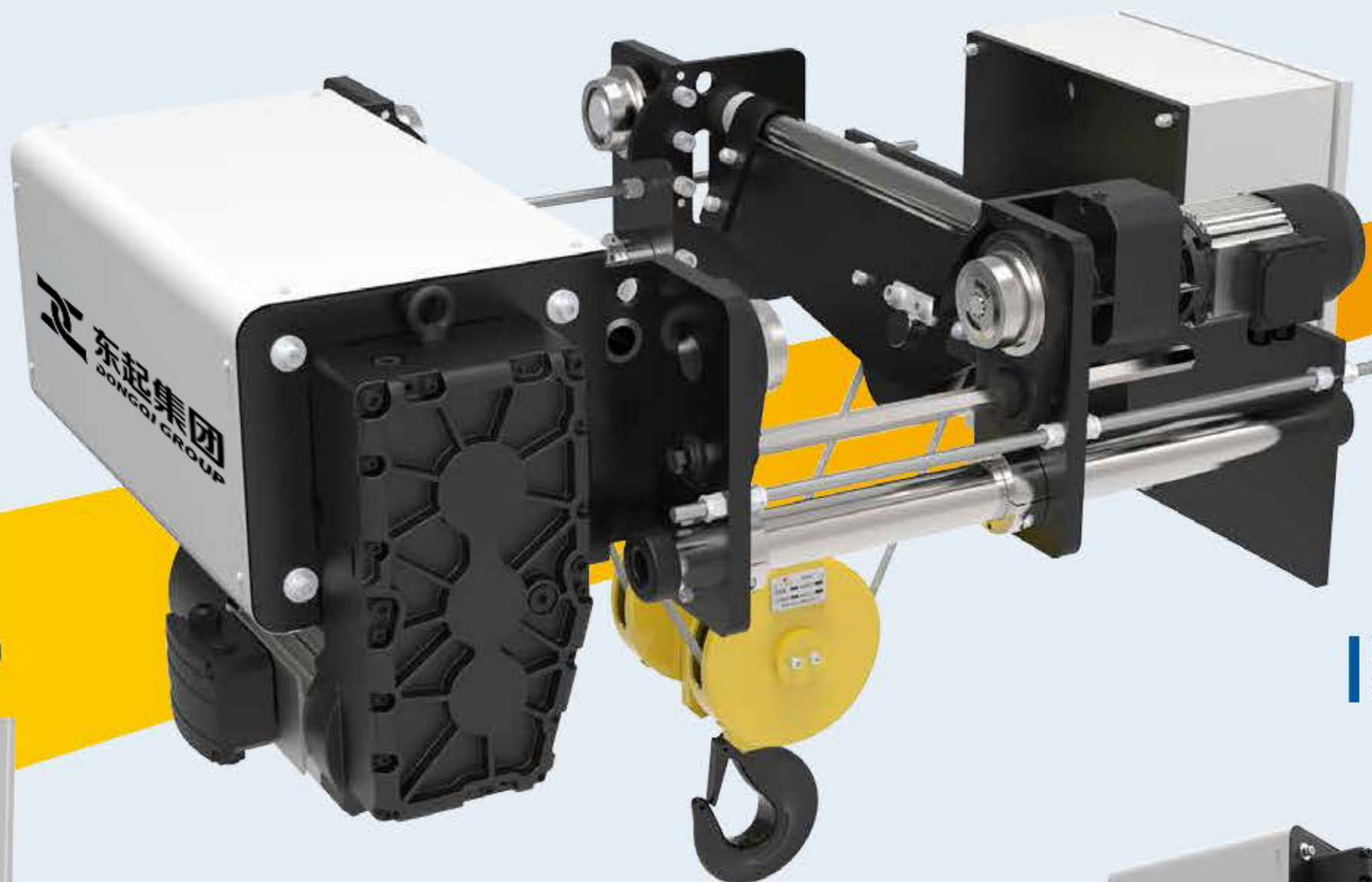

NRL 低净空运行式电动葫芦  
NRL Low-headroom Monorail Hoist



NRS 标准净空运行式电动葫芦  
NRS Standard Headroom Monorail Hoist



NRT 双梁小车式电动葫芦  
NRT Double-rail Crab



NRF 固定式电动葫芦  
NRF Foot-mounted Hoist



优势  
ADVANTAGE

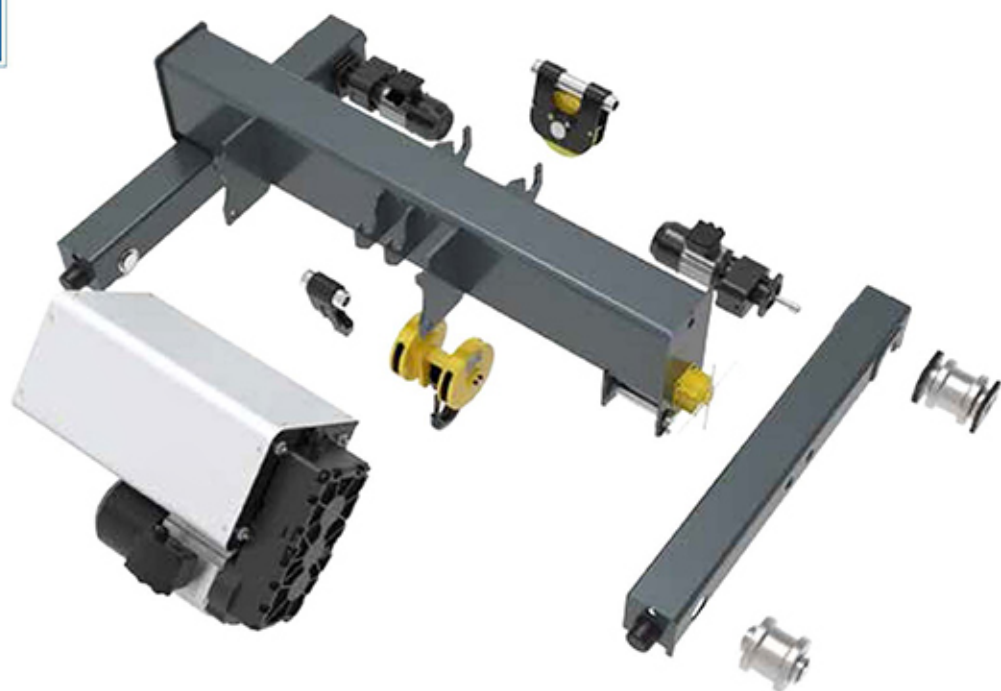

按照 ISO、GB、FEM、DIN、BS 等标准打造的全新一代电动葫芦产品：  
**NR 型钢丝绳电动葫芦**

## NR Type Wire Rope Electric Hoist:

A new generation Electric Hoist which fabricated according to ISO、GB、FEM、DIN、BS standards



核心技术自主可控设计理念 Autonomous and Controllable Design Concept of Core Technology



与重点高校研究机构合作开发核心零部件，并完全自主生产制造，实现产品品质可控、工期可控。

Cooperate with major university research institutes to develop core spare part, and can realize the independent production of core spare part, so as to achieve controllable product quality and controllable construction period.

1

起升驱动单元  
Lifting Drive Unit



3

安全监控器  
Security Monitor



2



运行驱动单元  
Travelling drive unit





减速器结构设计

Structure Design of Reducer

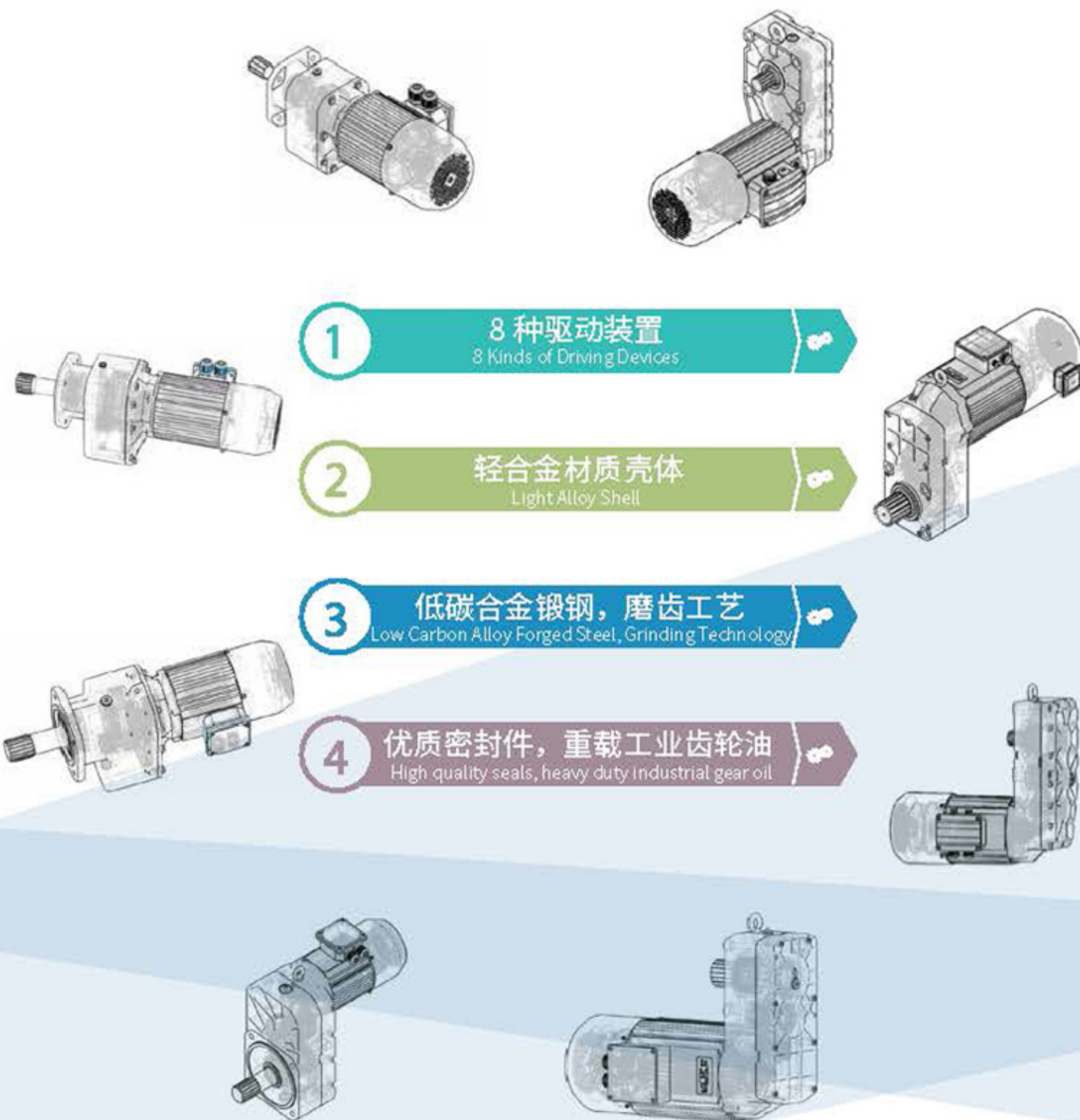

1 8 种驱动装置  
8 Kinds of Driving Devices

2 轻合金材质壳体  
Light Alloy Shell

3 低碳合金锻钢，磨齿工艺  
Low Carbon Alloy Forged Steel, Grinding Technology

4 优质密封件，重载工业齿轮油  
High quality seals, heavy duty industrial gear oil

电机结构设计和电磁计算

Structural Design and Electromagnetic Calculation of Motor

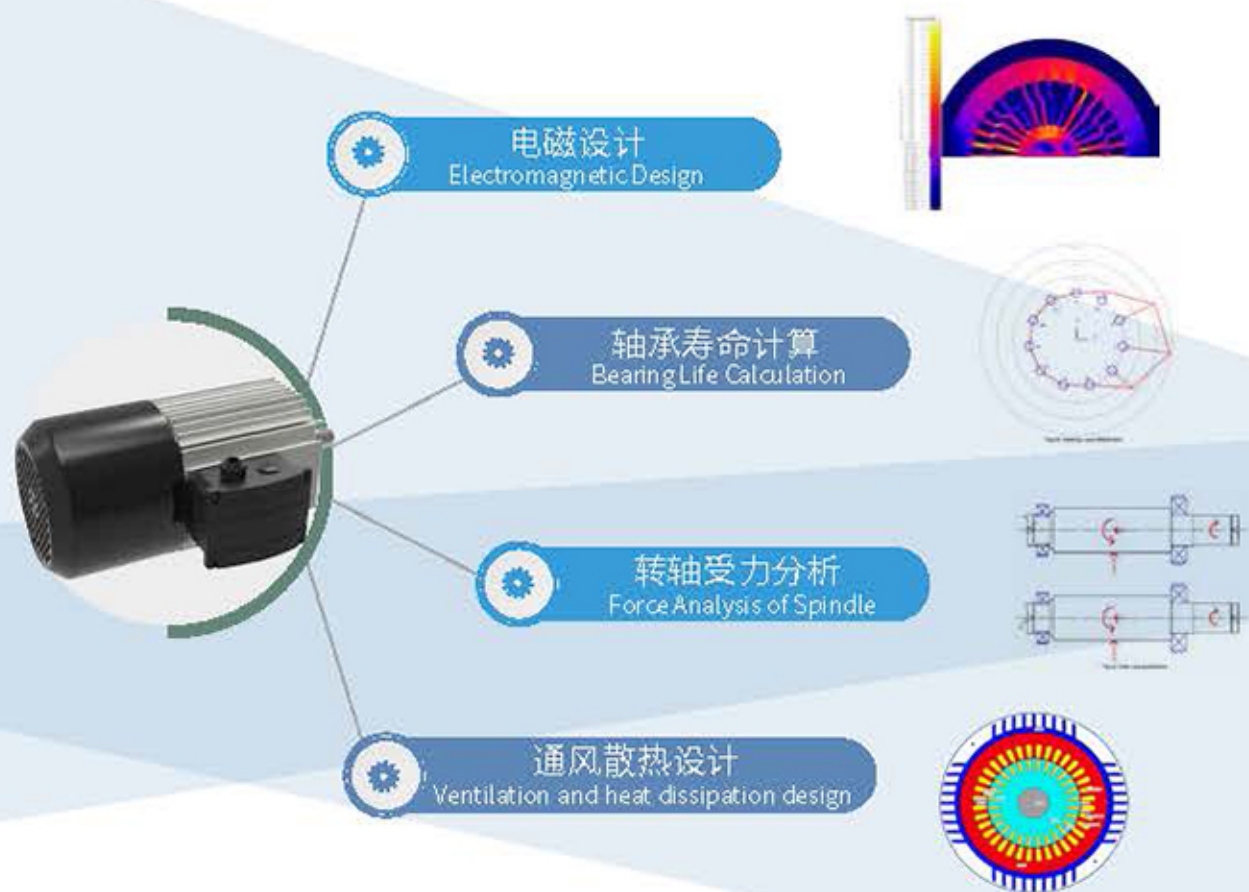



ASW 防摇系统 (第三代防摇摆控制系统) (Optional)

ASW Anti-Swing System  
(The Third Generation Anti-Swing Control System)



- 01** **功能升级**  
可替代 PLC 实现逻辑控制及电气防摇摆功能

**Function upgrade**  
It can replace PLC to realize logic control and electric anti-swing function
- 02** **高匹配性**  
不限制变频器品牌

**High Matching**  
No Restriction on Inverter brand
- 03** **成本优势**  
节约通讯卡、通讯线

**Cost advantage**  
Saving communication cards and lines

集中控制器

Integrated controller

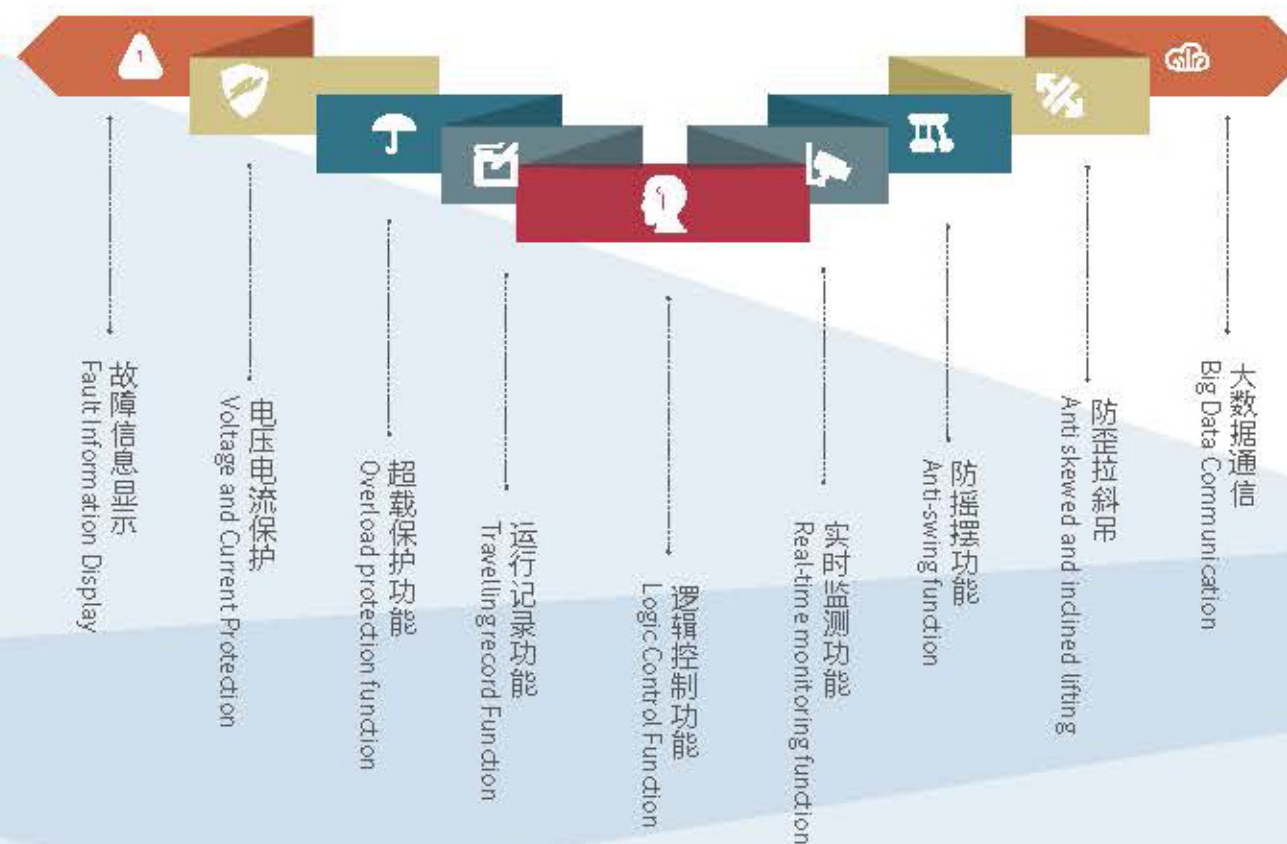



变频器

Frequency converter



起重机专用 For crane use only

小体积、小功率、高性价比  
It owns the features as follows: small volume, small power and high cost performance

支持性好 High support performance

支持开环矢量控制和 V/F 控制方式，起动力矩大  
It can support open-loop vector control and V/F control, the starting torque is large

特有控制功能 Special Control Function

配备起重驱动特有的报闸控制功能  
Equipped with special brake control function of crane driving system

应用范围广 Wide range of applications

起重设备的提升、平移、回转等驱动和控制场合  
It can be widely used in driving and controlling occasions such as the lifting, translation and rotation of lifting equipment

核心零部件“自主化”的优势

Independent Production of Core Components



模块化设计理念 Modular design concept



NR 型钢丝绳电动葫芦采用模块化结构，可以满足您的应用需求，其拥有前所未有的灵活性，可以为您提供个性化需求的完美解决方案。

NR Electric Hoist with modular structure can fully meet your requirements which owns unprecedented flexibility and can provide you with perfect solutions for personalized needs.





部件通用性强

Strong versatility of spare parts

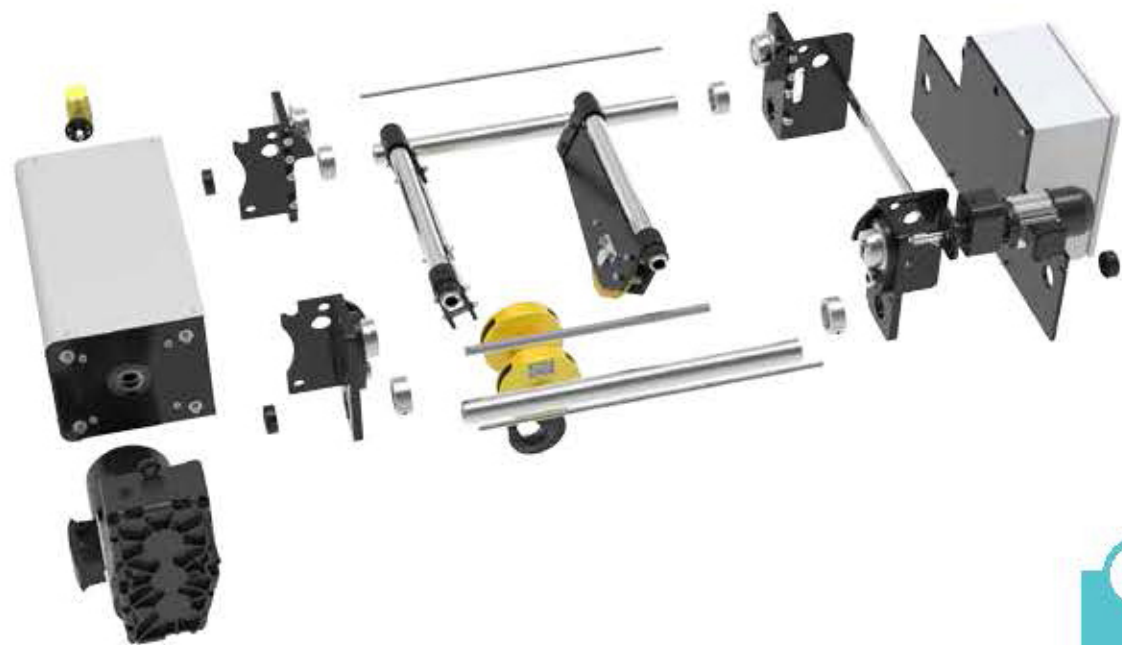

1  
五种结构车轮组  
Five kinds of Wheel sets

2  
四种起升三合一  
Four kinds of Hoisting Gear motor

3  
四种运行三合一  
Four kinds of Travelling Gear motor

新型起重机系列产品  
New Series Crane Products

NR 型系列钢丝绳电动葫芦  
NR series Steel Wire Rope Electric Hoist

HD 型电动单梁起重机  
HD Single Girder Overhead Crane

NLH 型电动葫芦桥式起重机  
NLH Overhead Crane with Electric Hoist



智能化、远程运维设计理念 Intelligent and remote operation and maintenance design concept



智能安全监控:

- ① 计算起升机构剩余安全工作周期
- ② 制动器安全工作次数
- ③ 累计设备起升及运行启动次数
- ④ 记录起升负载吨位
- ⑤ 过载保护, 禁止用户违规超载作业
- ⑥ 实时监测起重机运行电源情况
- ⑦ 电机过热保护
- ⑧ 可扩展无线网关, 接入用户大数据中心监控管理, 实现远程运维信息提示

Intelligent safety monitoring system has the advantage as follows: (Optional)

- ① Calculating the remaining safety cycle of lifting mechanism
- ② Brake safety operation times
- ③ Accumulated starts times of hoisting and travelling
- ④ Records the load tonnage
- ⑤ Overload protection, prohibit users from illegal overloading operations
- ⑥ Real-time monitoring of crane's operating Power Supply
- ⑦ Motor overheat protection
- ⑧ Extensible wireless access point, it can access to user's big data center monitoring management, so as to realize remote operation and maintenance



大数据管理, 云平台连接  
Big data management, cloud platform connection



全新一代安全监控系统:

- ★ 系统信息记录更精确: 计时计数、精确到秒、实时查询
- ★ 黑匣子功能: 故障记录、操作记录
- ★ 监控更全面: 监控外围设备、监控电源情况
- ★ 多路监控信号接入: 起重机状态、故障类别诊断
- ★ 即时通讯功能: 组网方便、远程传递信息
- ★ 输出更全面: 运行输出、故障输出、及时报警
- ★ 操作界面: 中英双语、实时时钟

A new generation of security monitoring system: (Optional)

- ★ More accurate recording of system information: timing and counting can be accurate to seconds, and real-time queries can also be realized
- ★ Black Box Function which can record the malfunctions and operations
- ★ More comprehensive monitoring: it can monitor peripheral equipment and power supply situation
- ★ Multi-channel monitoring signal access: crane condition, fault category diagnosis
- ★ Instant Messaging Function which owns the features as follows: convenient networking and remote information transmission
- ★ More comprehensive output such as: operation output, fault output, timely alarming
- ★ Operating Interface: Both in Chinese-English Language, Real-time Clock



安全监控器  
Security Monitor



电器元件布局图  
Electrical Component Layout



手机 APP 实时监控  
Mobile APP real-time monitoring

低净空、紧凑设计理念

Low headroom and compact design concept

4

所有系列均采用大直径卷筒, 可有效实现起升高度的增加和左右极限的缩小, 起重机工作盲区更小, 给用户提供更使用空间

All series Electric Hoist are equipped with large diameter drum, which can effectively increase the lifting height and reduce the left and right limits. Crane's dead zone when working becomes smaller, which can provide larger using space for the customers.

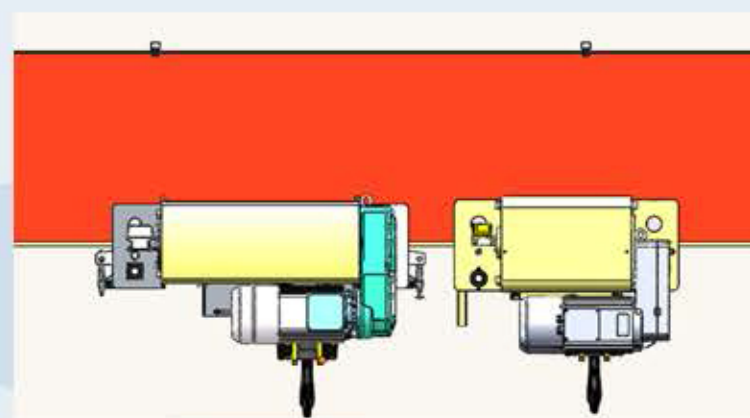
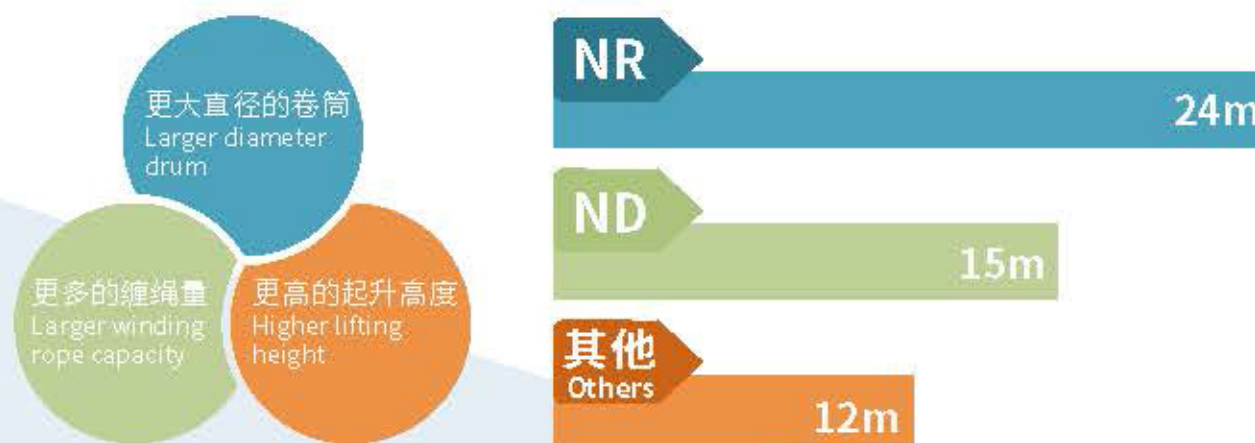

相同起升高度新老型号葫芦长度对比, NR 型葫芦 (右)  
Comparison of the length of Traditional and New Type Electric Hoist with the same lifting height, NR Type Electric Hoist (Right)



免维护、节能环保设计理念 Design concept of Maintenance-free, energy-saving and Green 5

结构紧凑  
Compact structure

重量减轻  
Reduce the deadweight

降低噪音  
Reduce noise

电机减速度器一体式结构设计  
Integral structure of Gear motor



电机功率较传统电动葫芦降低 30%  
The motor power is reduced by 30% compared with the traditional Electric Hoist



通过变频定位技术的成熟应用，使工作效率提高 20% 以上  
Through the mature application of Variable frequency positioning technology, the work efficiency is improved by more than 20%



整机噪音在 70 分贝以下  
The noise of the whole machine is below 70 decibels



制动器刹车片采用无石棉设计  
The brake pads adopt non-asbestos design



尼龙导绳器与钢丝绳、卷筒滑动摩擦不会产生金属粉尘，为工人提供高洁净操作空间  
No metal dust caused by the slide friction between the Nylon Rope Guide and Steel Wire Rope, drum, providing workers with high cleanness operation environment



高精度硬齿面减速机出厂已加注国际品牌润滑油，产品生命周期内无需更换  
The high-precision hard gear reducer has been filled with international brand lubricants before delivery from factory, and there is no need to replace it within the service cycle of the product



采用国际品牌免维护钢丝绳  
Adopt international brand and maintenance-free steel wire rope



高强尼龙导绳器，由易损件成为耐用品  
High-strength Nylon rope guides, change from wearing parts to durable parts



国际品牌电器元件、轴承、操作手柄  
International brand electrical components, bearings, and pendent controller



电磁盘式制动器具有刹车间隙自动补偿和免维护功能  
Electromagnetic disk brake with automatic compensation of brake clearance and maintenance-free function



操作手柄  
Pendent controller



导绳器  
Rope guide



制动器  
Brake





坚固耐用、安全设计理念 Rugged and safe design concept

6



整机通过国家标准寿命试验 (1600 小时)  
The whole machine passed the national standard life test (1600 hours)

电器元件机械寿命不低于 50 万次  
The service life of electrical components is not less than 500,000 times

制动器安全制动不低于 100 万次  
The safe use of brake reaching 1 million times

钢丝绳破断拉力不低于 2160 级  
The breaking force of the wire rope reaching grade 2160

吊钩采用高强 T 级钩头  
The hook adopts high-strength T-class hook head

减速器 10 年免维护  
10 years free maintenance of speed reducer



## 生产设备

PRODUCTION EQUIPMENTS



ZJH1200 真空浸漆烘干机  
ZJH1200 Vacuum Immersion Dryer



加高绝缘纸插入机  
Increased Insulating paper insert machine



绕线机  
Winding Machine



伺服双面绑线机  
Servo Double-sided Wire-binding Machine



德国 NILES 磨齿机  
German NILES Grinding Machine



滚齿线  
Gear Hobbing Production Line



三坐标测量仪  
Three coordinate measuring instrument



激光切割机  
Laser Cutting Machine





产品选型  
PRODUCT SELECTION

载荷类别 Load category				日平均工作时间 (小时) Average daily working time (hours)		
1	轻载: 极少吊运额定载荷, 经常吊运载荷很轻。 Light load: The rated load is rarely lifted and always handle the loads.			4~8	8~16	> 16
2	中载: 有时吊运额定载荷, 经常吊运载荷中等。 Medium load: The rated load is sometimes lifted and the frequency of load handling is medium.			2~4	4~8	8~16
3	重载: 经常需要吊运额定载荷, 经常吊运载荷较重。 Heavy load: The rated load is always lifted and the handling loads are always heavy.			1~2	2~4	4~8
4	特重载: 经常吊运额定载荷。 Super heavy load: always handling the rated load.			0.5~1	1~2	2~4
工作级别 Work duty				M5	M6	M7
滑轮倍率 Pulley ratio				型号 Model		
2/1	4/1	6/1	8/1			
4/2	8/2	12/2	16/2			
起重量 Lifting capacity						
1	2	—	—			
1.25	2.5	—	—			
1.5	3	—	—	NR1		
2	4	—	—			
2.5	5	—	—	NR2		
3.2	6.3	10	—			
4	8	12.5	—			
5	10	16	—	NR3		
6.3	12.5	20	25			
8	16	25	32			
10	20	32	40	NR4		
12.5	25	40	50			
16	32	50	63			
20	40	63	80	NR5		

日平均工作时间可由下式计算:

Average daily working time can be calculated by the following formula:

$$T_m = \frac{2 \times \text{吊钩行程 (m)} \times \text{每小时循环次数} \times \text{日工作时间}}{60 \times \text{起升速度 (m/min)}}$$

$$T_m = \frac{2 \times \text{Travelling distance of Hook} \times \text{Number of cycles per hour} \times \text{Working hours per day}}{60 \times \text{Lifting speed (m/min)}}$$

实例  
example

起重量	10t
载荷类型	中等载荷
起升速度	5m/min
滑轮倍率	4/1
吊钩平均行程	估计为 6m
每小时循环次数	估计为 12 次
日工作时间	8 小时
载荷类型	中载

Lifting capacity	10t
Load category	Medium load
Lifting speed	5m/min
Pulley ratio	4/1
Average travelling distance of hook	Estimated to be 6m
Number of cycles per hour	Estimated to be 12 times
Daily working day	8 hours
Load category	Medium load

$$T_m = \frac{2 \times 6 \times 12 \times 8}{60 \times 5} = 3.84 \text{ 小时(hour)}$$

表中给出工作级别为M5, 起重量为10t和滑轮倍率为4/1, 表中给出型号NR3。  
The working level is M5, the lifting capacity is 10t and the pulley ratio is 4/1. The model NR3 is given in the table.



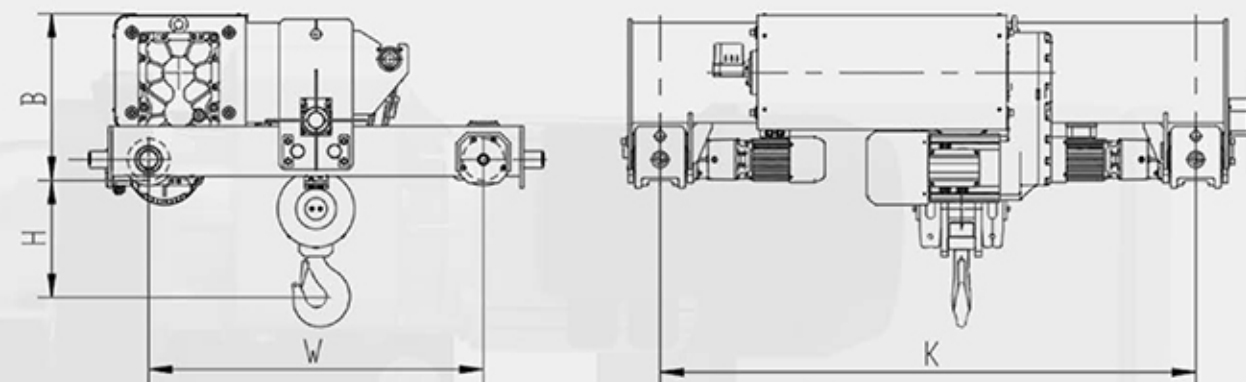
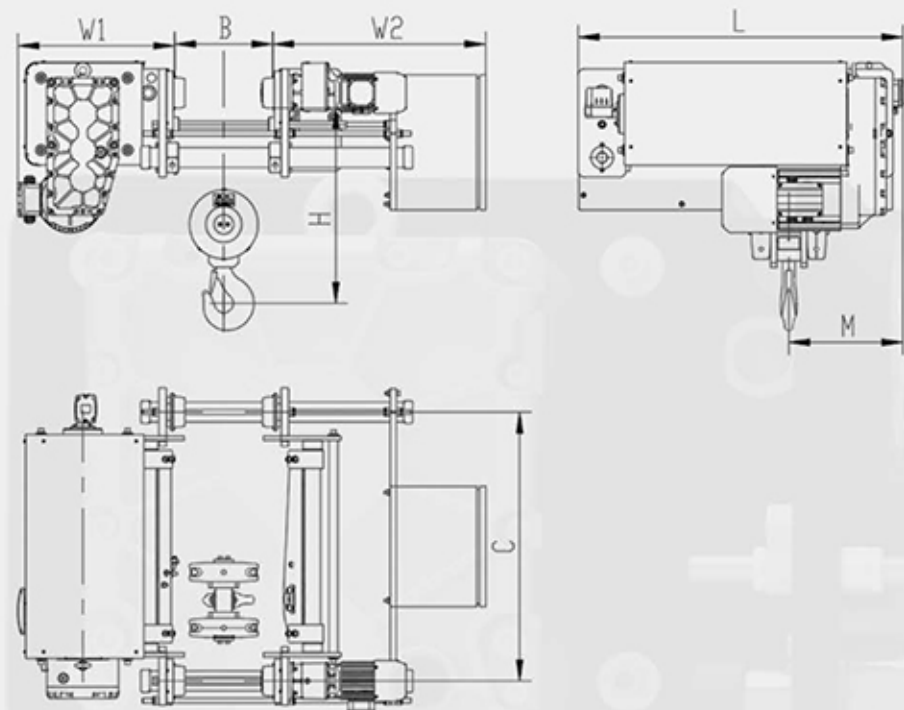

NRT系列小车参数表  
NRT series trolley parameter table

起重量 (t) Capacity(t)	工作级别 Work duty	起升速度 (m/min) Lifting speed	起升高度 (m) Lifting height (m)	出绳方式 Number of falls	运行速度 (m/min) Travelling speed (m/min)	小车高度 Height of trolley B(mm)	吊钩上极限 Hook upper limit H(mm)	小车基距 Trolley wheel gauge W(mm)	小车轨距 Trolley gauge K(mm)
5	M5	5/0.8	≤ 24	4/1	2~20	500	330	1000	1600 2200
10	M5	5/0.8	≤ 24	4/1	2~20	605	520	1000	
16	M5	3.3/0.53	≤ 16	6/1	2~20	700	860	1300	
16	M5	5/0.8	≤ 24	4/1	2~20	670	800	1300	2000 2500 3000
20	M5	5/0.8	≤ 24	4/1	2~20	670	800	1300	
32	M5	3.3/0.5	≤ 16	6/1	2~20	750	975	1300	
32	M5	5/0.8	≤ 24	8/2	2~20	720	1075	1300	2500 3000 3250 3750 4250
40	M5	5/0.8	≤ 24	8/2	2~20	720	1075	1300	
50	M5	3.3/0.5	≤ 24	12/2	2~20	770	1100	1400	
63	M5	2.4/0.4	≤ 21	16/2	2~20	770	1100	1400	2500 3000 3250 3750 4250
80	M5	2.4/0.4	≤ 21	16/2	2~20	785	1150	1600	

NRL系列低净空葫芦参数表  
NRL series low headroom hoist parameter table

起重量 (t) Capacity (t)	工作级别 Work duty	起升速度 (m/min) Lifting speed (m/min)	起升高度 (m) Lifting height (m)	出绳方式 Number of falls	运行速度 Travelling speed (m/min)	轨道宽度 B(mm)	吊钩上极限 Hook upper limit H(mm)	葫芦宽度 Hoist width W1/W2 (mm)	吊钩右极限 Hook right limit M(mm)	葫芦总长 Hoist length L(mm)	葫芦轮距 Hoist wheel gauge C(mm)
3	M5	5/0.8	6	4/1	2~20	120~350	550	483 538	342	863	670
			9								850
			12								1030
			15								1210
			18								1390
			24								1750
5	M5	5/0.8	6	4/1	2~20	120~450	526 713	382	798	605	
			9							750	
			12							895	
			15							1040	
			18							1185	
			24							1475	
10	M5	5/0.8	9	4/1	2~20	250~550	560 590	380	1010	790	
			12							910	
			15							1030	
			18							1150	
			24							1390	