

## Explosion-proof Electric Chain Hoist



### OREP Series

- 01 OREP Hook Type
- 07 OREP Hoist with Electric Trolley
- 13 OREP Super Low Headroom Hoist
- 19 OREP Double Speed Hoist Specifications

**Henan Yuantai Crane Machinery  
Import&Export Co., Ltd.**



YUANTAI CRANE

+86-371-65760775

ytcranes

yuantai@ytcrane.com

www.ytcrane.com

Address: Room 2005, Building 3A, Shenglong Plaza,  
Zhengzhou City, China.

# OREP Series HOOK TYPE 挂钩式



## 1-5T BT4

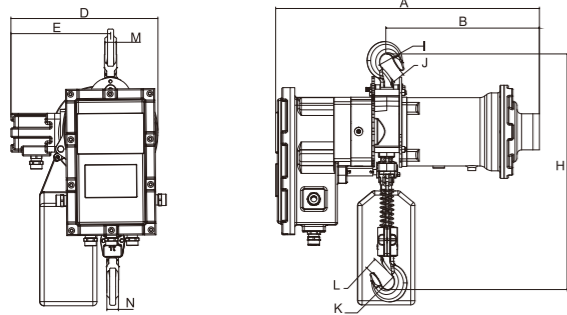

### Technical Parameters

防爆标志 Ex d II BT4 Gb/Ex tD A21 IP65 T130°C

型号 Type	容量 Capacity (Ton)	起升高度 Lifting Height (m)	起升速度 Lifting speed (m/min)	起升电机 Lifting Motor				
				功率 Power (kw)	转速 Rotation speed (r/min)	相位 Phases	电压 voltage (V)	频率 Frequency (Hz)
OREP-B-01-01	1	3/9	6.8	1.5	1440	3	220-440	50/60
OREP-B-02-02	2	3/9	3.4	1.5	1440	3	220-440	50/60
OREP-B-02-01	2	3/9	6.6	3.0	1440	3	220-440	50/60
OREP-B-03-03	3	3/9	2.2	1.5	1440	3	220-440	50/60
OREP-B-03-02	3	3/9	3.3	3.0	1440	3	220-440	50/60
OREP-B-03-01	3	3/9	5.6	3.0	1440	3	220-440	50/60
OREP-B-05-02	5	3/9	2.8	3.0	1440	3	220-440	50/60

### Product Size

Unit(mm)

型号Type	容量Capacity	H	A	B	D	E	I	J	K	L	N	M	CHAIN
OREP-C-01-01	1	600	700	405	380	235	φ40	31	φ40	31	24	24	φ7.1
OREP-C-02-02	2	750	700	405	380	235	φ49	35	φ49	35	30	30	φ7.1
OREP-C-02-01	2	800	825	460	460	250	φ59	35	φ49	35	30	30	φ10.0
OREP-C-03-03	3	1000	700	460	460	295	φ59	42	φ59	42	35	35	φ7.1
OREP-C-03-02	3	950	825	460	460	290	φ59	42	φ59	42	35	35	φ10.0
OREP-C-03-01	3	845	825	460	460	250	φ59	42	φ59	42	35	35	φ11.2
OREP-C-05-02	5	1030	825	460	460	290	φ60	45	φ60	45	43	43	φ11.2

## 1-5T BT4

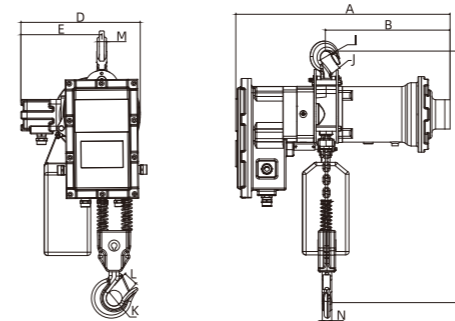

### Technical Parameters

防爆标志 Ex d II BT4 Gb/Ex tD A21 IP65 T130°C

型号 Type	容量 Capacity (Ton)	起升高度 Lifting Height (m)	起升速度 Lifting speed (m/min)	起升电机 Lifting Motor				
				功率 Power (kw)	转速 Rotation speed (r/min)	相位 Phases	电压 voltage (V)	频率 Frequency (Hz)
OREP-B-01-01	1	3/9	6.8	1.5	1440	3	220-440	50/60
OREP-B-02-02	2	3/9	3.4	1.5	1440	3	220-440	50/60
OREP-B-02-01	2	3/9	6.6	3.0	1440	3	220-440	50/60
OREP-B-03-03	3	3/9	2.2	1.5	1440	3	220-440	50/60
OREP-B-03-02	3	3/9	3.3	3.0	1440	3	220-440	50/60
OREP-B-03-01	3	3/9	5.6	3.0	1440	3	220-440	50/60
OREP-B-05-02	5	3/9	2.8	3.0	1440	3	220-440	50/60

### Product Size

Unit(mm)

型号Type	容量Capacity	H	A	B	D	E	I	J	K	L	N	M	CHAIN
OREP-C-01-01	1	600	700	405	380	235	φ40	31	φ40	31	24	24	φ7.1
OREP-C-02-02	2	750	700	405	380	235	φ49	35	φ49	35	30	30	φ7.1
OREP-C-02-01	2	800	825	460	460	250	φ59	35	φ49	35	30	30	φ10.0
OREP-C-03-03	3	1000	700	460	460	295	φ59	42	φ59	42	35	35	φ7.1
OREP-C-03-02	3	950	825	460	460	290	φ59	42	φ59	42	35	35	φ10.0
OREP-C-03-01	3	845	825	460	460	250	φ59	42	φ59	42	35	35	φ11.2
OREP-C-05-02	5	1030	825	460	460	290	φ60	45	φ60	45	43	43	φ11.2

### 7.5T BT4/CT4

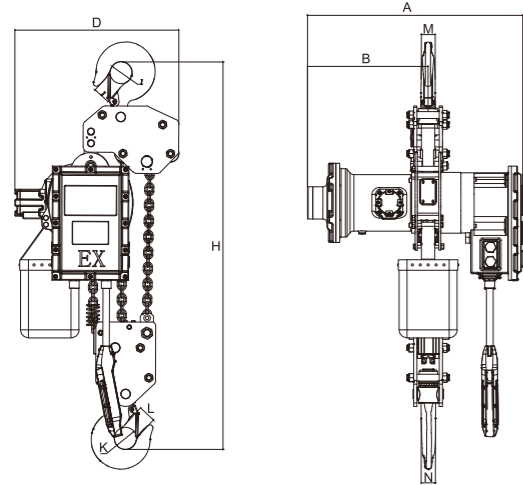

防爆标志Ex d II BT4 Gb/Ex tD A21 IP65 T130°C  
 防爆标志Ex d II CT4 Gb/Ex tD A21 IP65 T130°C

#### Technical Parameters

型号 Type	容量 Capacity (Ton)	起升高度 Lifting Height (m)	起升速度 Lifting speed (m/min)	起升电机 Lifting Motor				
				功率 Power (kw)	转速 Rotation speed (r/min)	相位 Phases	电压 voltage (V)	频率 Frequency (Hz)
OREP-B-7.5-03	7.5	3/9	1.8	3.0	1440	3	220-440	50/60
OREP-C-7.5-03	7.5	3/9	1.8	3.0	1440	3	220-440	50/60

#### Product Size

型号Type	容量Capacity	H	A	B	D	I	J	K	L	N	M	Unit(mm)	
OREP-B-7.5-03	7.5	1280	825	460	625	φ83	68	φ83	68	55	55		
OREP-C-7.5-03	7.5	1280	855	460	625	φ83	68	φ83	68	55	55		

### 1-5T CT4

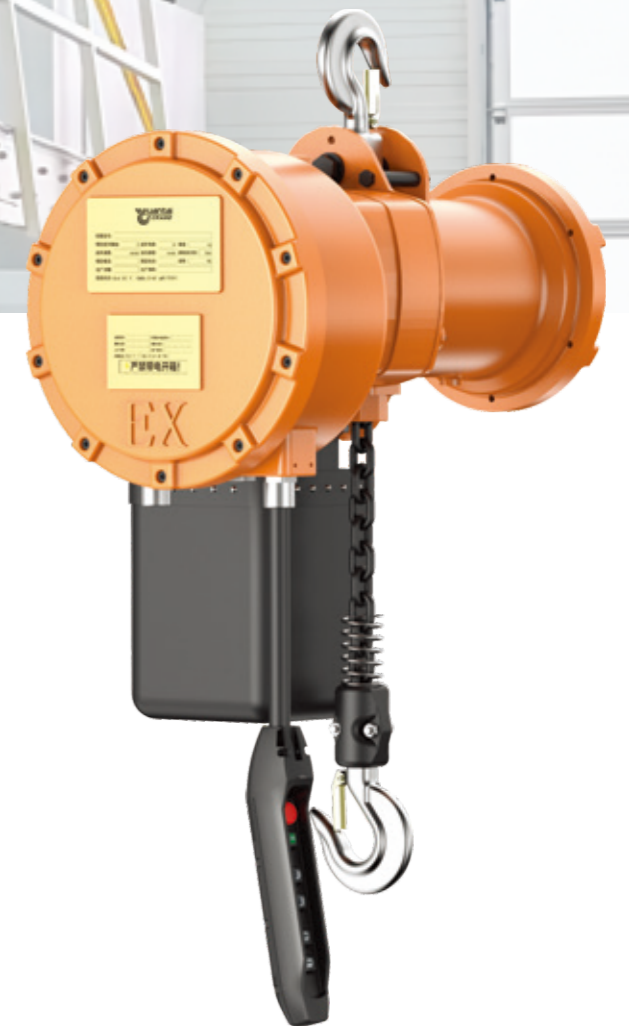
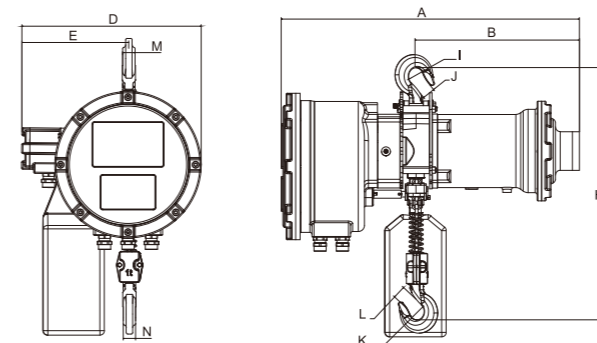

#### Technical Parameters

防爆标志Ex d II CT4 Gb/Ex tD A21 IP65 T130°C

型号 Type	容量 Capacity (Ton)	起升高度 Lifting Height (m)	起升速度 Lifting speed (m/min)	起升电机 Lifting Motor				
				功率 Power (kw)	转速 Rotation speed (r/min)	相位 Phases	电压 voltage (V)	频率 Frequency (Hz)
OREP-C-01-01	1	3/9	6.8	1.5	1440	3	220-440	50/60
OREP-C-02-02	2	3/9	3.4	1.5	1440	3	220-440	50/60
OREP-C-02-01	2	3/9	6.6	3.0	1440	3	220-440	50/60
OREP-C-03-03	3	3/9	2.2	1.5	1440	3	220-440	50/60
OREP-C-03-02	3	3/9	3.3	3.0	1440	3	220-440	50/60
OREP-C-03-01	3	3/9	5.6	3.0	1440	3	220-440	50/60
OREP-C-05-02	5	3/9	2.8	3.0	1440	3	220-440	50/60

#### Product Size

Unit(mm)

型号Type	容量Capacity	H	A	B	D	E	I	J	K	L	N	M	CHAIN
OREP-C-01-01	1	600	745	405	410	235	φ40	31	φ40	31	24	24	φ7.1
OREP-C-02-02	2	750	745	405	410	235	φ49	35	φ49	35	30	30	φ7.1
OREP-C-02-01	2	800	855	458	460	250	φ59	35	φ49	35	30	30	φ10.0
OREP-C-03-03	3	1000	745	460	460	295	φ59	42	φ59	42	35	35	φ7.1
OREP-C-03-02	3	950	855	460	460	290	φ59	42	φ59	42	35	35	φ10.0
OREP-C-03-01	3	845	855	460	460	250	φ59	42	φ59	42	35	35	φ11.2
OREP-C-05-02	5	1030	855	460	460	290	φ60	45	φ60	45	43	43	φ11.2

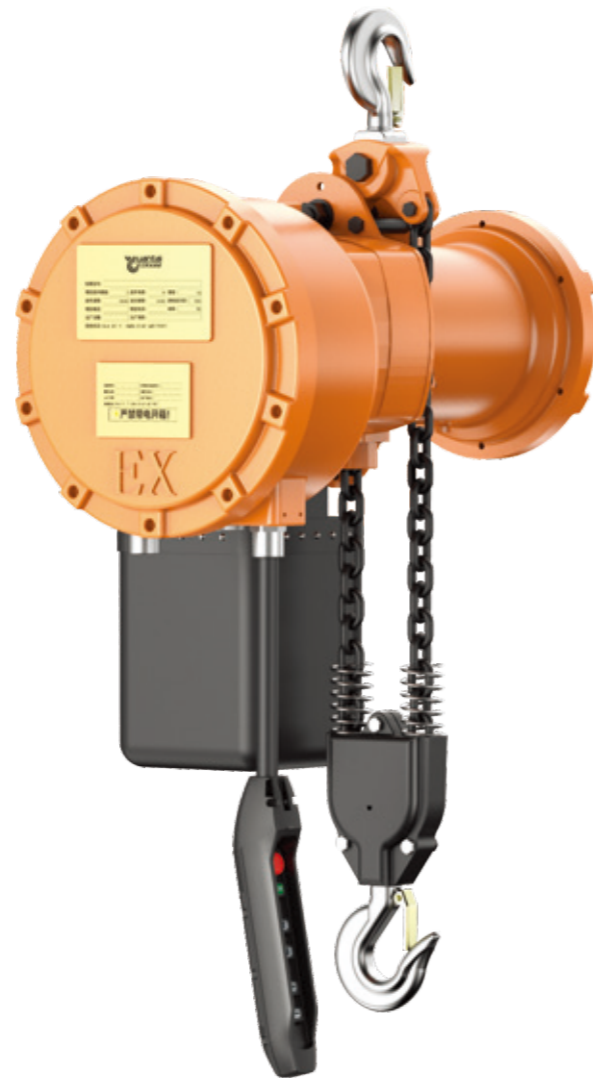

**1-5T CT4**

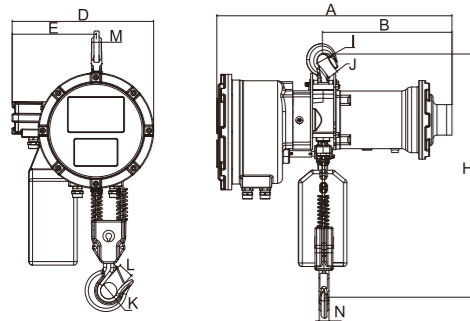

Technical Parameters

防爆标志Ex d II CT4 Gb/Ex tD A21 IP65 T130°C

型号 Type	容量 Capacity (Ton)	起升高度 Lifting Height (m)	起升速度 Lifting speed (m/min)	起升电机 Lifting Motor				
				功率 Power (kw)	转速 Rotation speed (r/min)	相位 Phases	电压 voltage (V)	频率 Frequency (Hz)
OREP-C-01-01	1	3/9	6.8	1.5	1440	3	220-440	50/60
OREP-C-02-02	2	3/9	3.4	1.5	1440	3	220-440	50/60
OREP-C-02-01	2	3/9	6.6	3.0	1440	3	220-440	50/60
OREP-C-03-03	3	3/9	2.2	1.5	1440	3	220-440	50/60
OREP-C-03-02	3	3/9	3.3	3.0	1440	3	220-440	50/60
OREP-C-03-01	3	3/9	5.6	3.0	1440	3	220-440	50/60
OREP-C-05-02	5	3/9	2.8	3.0	1440	3	220-440	50/60

Product Size

Unit(mm)

型号Type	容量Capacity	H	A	B	D	E	I	J	K	L	N	M	CHAIN
OREP-C-01-01	1	600	745	405	410	235	φ40	31	φ40	31	24	24	φ7.1
OREP-C-02-02	2	750	745	405	410	235	φ49	35	φ49	35	30	30	φ7.1
OREP-C-02-01	2	800	855	460	460	250	φ59	35	φ49	35	30	30	φ10.0
OREP-C-03-03	3	1000	745	460	460	295	φ59	42	φ59	42	35	35	φ7.1
OREP-C-03-02	3	950	855	460	460	290	φ59	42	φ59	42	35	35	φ10.0
OREP-C-03-01	3	845	855	460	460	250	φ59	42	φ59	42	35	35	φ11.2
OREP-C-05-02	5	1030	855	460	460	290	φ60	45	φ60	45	43	43	φ11.2

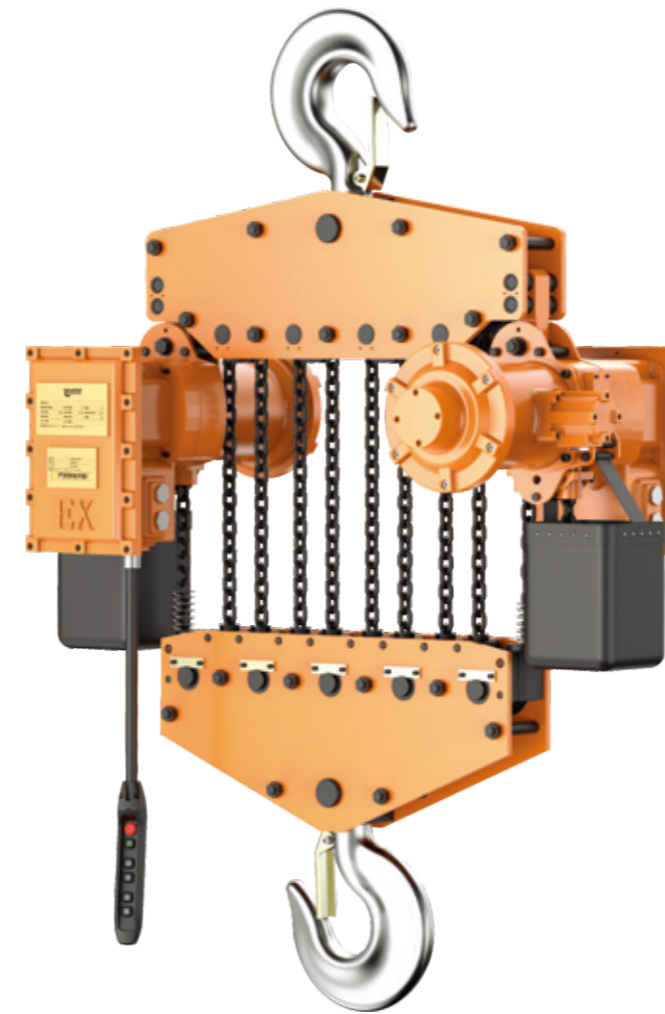

**10-25T BT4/CT4**

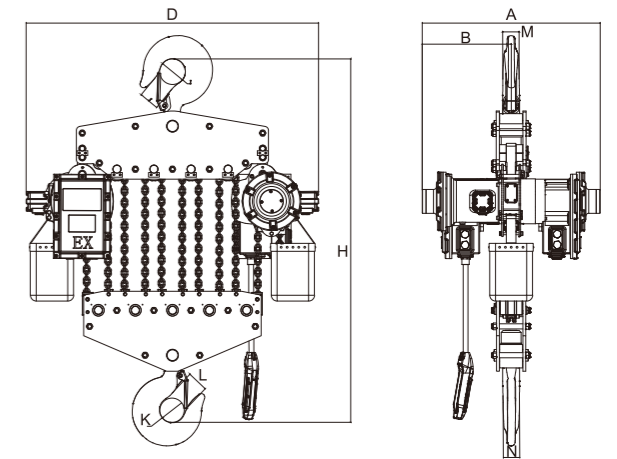

防爆标志Ex d II BT4 Gb/Ex tD A21 IP65 T130°C

防爆标志Ex d II CT4 Gb/Ex tD A21 IP65 T130°C

Technical Parameters

型号 Type	容量 Capacity (Ton)	起升高度 Lifting Height (m)	起升速度 Lifting speed (m/min)	起升电机 Lifting Motor				
				功率 Power (kw)	转速 Rotation speed (r/min)	相位 Phases	电压 voltage (V)	频率 Frequency (Hz)
OREP-B-10-04	10	3/9	2.8	3x2	1440	3	220-440	50/60
OREP-B-15-06	15	3/9	1.8	3x2	1440	3	220-440	50/60
OREP-B-20-08	20	3/9	1.4	3x2	1440	3	220-440	50/60
OREP-B-25-10	25	3/9	1.1	3x2	1440	3	220-440	50/60
OREP-C-10-04	10	3/9	2.8	3x2	1440	3	220-440	50/60
OREP-C-15-06	15	3/9	1.8	3x2	1440	3	220-440	50/60
OREP-C-20-08	20	3/9	1.4	3x2	1440	3	220-440	50/60
OREP-C-25-10	25	3/9	1.1	3x2	1440	3	220-440	50/60

Product Size

Unit(mm)

型号Type	容量Capacity	H	A	B	D	I	J	K	L	N	M
OREP-B-10-04	10	1400	920	460	940	φ83	68	φ83	68	55	55
OREP-B-15-06	15	1580	920	460	1110	φ115	90	φ115	90	72	72
OREP-B-20-08	20	1670	920	460	1300	φ115	90	φ115	90	72	72
OREP-B-25-10	25	1670	920	460	1500	φ142	110	φ142	110	85	85
OREP-C-10-04	10	1400	920	460	940	φ83	68	φ83	68	85	55
OREP-C-15-06	15	1580	920	460	1110	φ115	90	φ115	90	72	72
OREP-C-20-08	20	1670	920	460	1300	φ115	90	φ115	90	72	72
OREP-C-25-10	25	1670	920	460	1500	φ142	110	φ142	100	85	85

# OREP Series HOIST WITH ELECTRIC TROLLEY

## 运行式



1-5T BT4

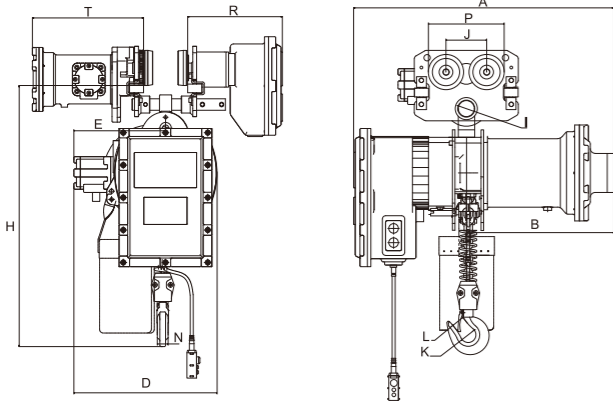

Technical Parameters

防爆标志Ex d II BT4 Gb/Ex tD A21 IP65 T130°C

型号 Type	容量 Capacity (Ton)	起升高度 Lifting height (m)	起升速度 Lifting speed (m/min)	起升电机 Lifting Motor					操作电机 Operating Motor				
				功率 Power (kw)	转速 Rotation speed (r/min)	相位 Phases	电压 voltage (V)	频率 Frequency (Hz)	功率 Power (kw)	转速 Rotation speed (r/min)	相位 Phases	电压 voltage (V)	频率 Frequency (Hz)
OREP-B-01-01	1	3/9	6.8	1.5	1440	3	220-440	50/60	0.4	1440	3	220-440	50/60
OREP-B-02-02	2	3/9	3.4	1.5	1440	3	220-440	50/60	0.4	1440	3	220-440	50/60
OREP-B-02-01	2	3/9	6.6	3.0	1440	3	220-440	50/60	0.4	1440	3	220-440	50/60
OREP-B-03-03	3	3/9	2.2	1.5	1440	3	220-440	50/60	0.75	1440	3	220-440	50/60
OREP-B-03-02	3	3/9	3.3	3.0	1440	3	220-440	50/60	0.75	1440	3	220-440	50/60
OREP-B-03-01	3	3/9	5.6	3.0	1440	3	220-440	50/60	0.75	1440	3	220-440	50/60
OREP-B-05-02	5	3/9	2.8	3.0	1440	3	220-440	50/60	0.75	1440	3	220-440	50/60

Product Size

Unit(mm)

型号Type	H	A	B	D	E	I	J	K	L	N	P	R	T	Chain	工字钢I-BEAM
OREP-B-01-01	650	700	405	380	235	φ31	111	φ40	31	24	206	300	360	φ7.1	80-160
OREP-B-02-02	740	700	405	380	235	φ36	127	φ49	35	30	237	302	362	φ7.1	82-178
OREP-B-02-01	770	825	460	460	250	φ36	127	φ49	35	30	237	302	362	φ10.0	82-178
OREP-B-03-03	1000	700	460	460	295	φ43	140	φ59	42	35	265	305	365	φ10.0	110-178
OREP-B-03-02	940	825	460	460	290	φ43	140	φ59	42	35	265	305	365	φ11.2	100-180
OREP-B-03-01	840	825	460	460	250	φ43	140	φ59	42	35	265	305	365	φ11.2	100-180
OREP-B-05-02	1015	825	460	460	290	φ54	156	φ60	45	43	296	312	372	φ11.2	110-180



1-5T BT4

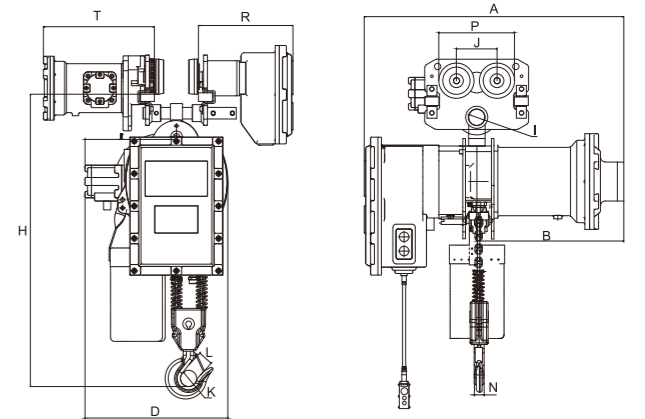

Technical Parameters

防爆标志Ex d II BT4 Gb/Ex tD A21 IP65 T130°C

型号 Type	容量 Capacity (Ton)	起升高度 Lifting height (m)	起升速度 Lifting speed (m/min)	起升电机 Lifting Motor					操作电机 Operating Motor				
				功率 Power (kw)	转速 Rotation speed (r/min)	相位 Phases	电压 voltage (V)	频率 Frequency (Hz)	功率 Power (kw)	转速 Rotation speed (r/min)	相位 Phases	电压 voltage (V)	频率 Frequency (Hz)
OREP-B-01-01	1	3/9	6.8	1.5	1440	3	220-440	50/60	0.4	1440	3	220-440	50/60
OREP-B-02-02	2	3/9	3.4	1.5	1440	3	220-440	50/60	0.4	1440	3	220-440	50/60
OREP-B-02-01	2	3/9	6.6	3.0	1440	3	220-440	50/60	0.4	1440	3	220-440	50/60
OREP-B-03-03	3	3/9	2.2	1.5	1440	3	220-440	50/60	0.75	1440	3	220-440	50/60
OREP-B-03-02	3	3/9	3.3	3.0	1440	3	220-440	50/60	0.75	1440	3	220-440	50/60
OREP-B-03-01	3	3/9	5.6	3.0	1440	3	220-440	50/60	0.75	1440	3	220-440	50/60
OREP-B-05-02	5	3/9	2.8	3.0	1440	3	220-440	50/60	0.75	1440	3	220-440	50/60

Product Size

Unit(mm)

型号Type	H	A	B	D	E	I	J	K	L	N	P	R	T	Chain	工字钢I-BEAM
OREP-B-01-01	650	700	405	380	235	φ31	111	φ40	31	24	206	300	360	φ7.1	80-160
OREP-B-02-02	740	700	405	380	235	φ36	127	φ49	35	30	237	302	362	φ7.1	82-178
OREP-B-02-01	770	825	460	460	250	φ36	127	φ49	35	30	237	302	362	φ10.0	82-178
OREP-B-03-03	1000	700	460	460	295	φ43	140	φ59	42	35	265	305	365	φ10.0	110-178
OREP-B-03-02	940	825	460	460	290	φ43	140	φ59	42	35	265	305	365	φ11.2	100-180
OREP-B-03-01	840	825	460	460	250	φ43	140	φ59	42	35	265	305	365	φ11.2	100-180
OREP-B-05-02	1015	825	460	460	290	φ54	156	φ60	45	43	296	312	372	φ11.2	110-180

**7.5T BT4/CT4**

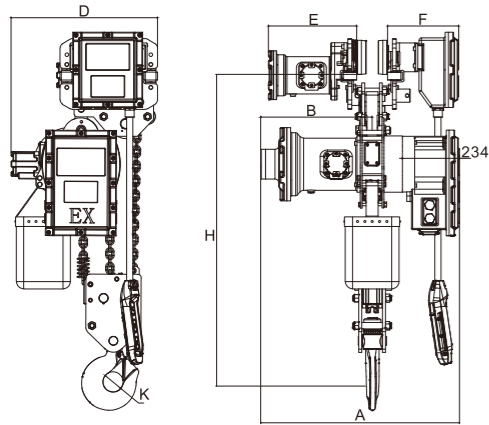

防爆标志Ex d II BT4 Gb/Ex tD A21 IP65 T130°C  
 防爆标志Ex d II CT4 Gb/Ex tD A21 IP65 T130°C

Technical Parameters

型号 Type	容量 Capacity (Ton)	起升高度 Lifting Height (m)	起升速度 Lifting speed (m/min)	起升电机 Lifting Moter					移动速度 Traveling speed (m/min)	操作电机 Operating Moter				
				功率 Power (kw)	转速 Rotation speed (r/min)	相位 Phases	电压 voltage (V)	频率 Frequency (Hz)		功率 Power (kw)	转速 Rotation speed (r/min)	相位 Phases	电压 voltage (V)	频率 Frequency (Hz)
OREP-B-7.5-03	7.5	3/9	1.8	3	1440	3	220-440	50/60	10/20	0.75	1440	3	220-440	50/60
OREP-C-7.5-03	7.5	3/9	1.8	3	1440	3	220-440	50/60	10/20	0.75	1440	3	220-440	50/60

Product Size

型号Type	容量Capacity	H	A	B	D	E	F	K	L	N
OREP-B-7.5-03	3	1200	825	460	600	372	312	φ83	68	55
OREP-C-7.5-03	3	1200	855	460	600	372	327	φ83	68	55

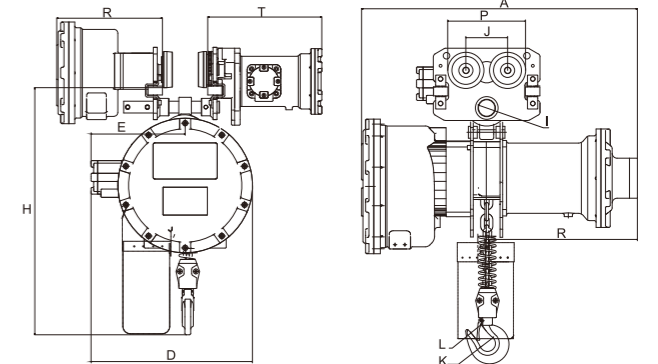

**1-5T CT4**

防爆标志Ex d II CT4 Gb/Ex tD A21 IP65 T130°C

Technical Parameters

型号 Type	容量 Capacity (Ton)	起升高度 Lifting Height (m)	起升速度 Lifting speed (m/min)	起升电机 Lifting Moter					操作电机 Operating Moter				
				功率 Power (kw)	转速 Rotation speed (r/min)	相位 Phases	电压 voltage (V)	频率 Frequency (Hz)	功率 Power (kw)	转速 Rotation speed (r/min)	相位 Phases	电压 voltage (V)	频率 Frequency (Hz)
OREP-C-01-01	1	3/9	6.8	1.5	1440	3	220-440	50/60	0.4	1440	3	220-440	50/60
OREP-C-02-02	2	3/9	3.4	1.5	1440	3	220-440	50/60	0.4	1440	3	220-440	50/60
OREP-C-02-01	2	3/9	6.6	3.0	1440	3	220-440	50/60	0.4	1440	3	220-440	50/60
OREP-C-03-03	3	3/9	2.2	1.5	1440	3	220-440	50/60	0.75	1440	3	220-440	50/60
OREP-C-03-02	3	3/9	3.3	3.0	1440	3	220-440	50/60	0.75	1440	3	220-440	50/60
OREP-C-03-01	3	3/9	5.6	3.0	1440	3	220-440	50/60	0.75	1440	3	220-440	50/60
OREP-C-05-02	5	3/9	2.8	3.0	1440	3	220-440	50/60	0.75	1440	3	220-440	50/60

Product Size

型号Type	H	A	B	D	E	I	J	K	L	N	P	R	T	Chain	I-BEAM
OREP-C-01-01	650	745	405	410	235	φ31	111	φ40	31	24	206	315	360	φ71	100-160
OREP-C-02-02	740	745	405	410	235	φ36	127	φ49	35	30	237	317	362	φ71	100-160
OREP-C-02-01	770	855	460	460	250	φ36	127	φ49	35	30	237	317	362	φ10.0	100-160
OREP-C-03-03	1000	745	405	410	295	φ43	140	φ59	42	35	265	320	365	φ71	120-180
OREP-C-03-02	940	855	460	460	290	φ43	140	φ59	42	35	265	320	365	φ11.2	120-180
OREP-C-03-01	840	855	460	460	250	φ43	140	φ59	42	35	265	320	365	φ11.2	120-180
OREP-C-05-02	1015	855	460	460	290	φ54	156	φ59	45	42	296	327	372	φ11.2	120-180

**1-5T CT4**

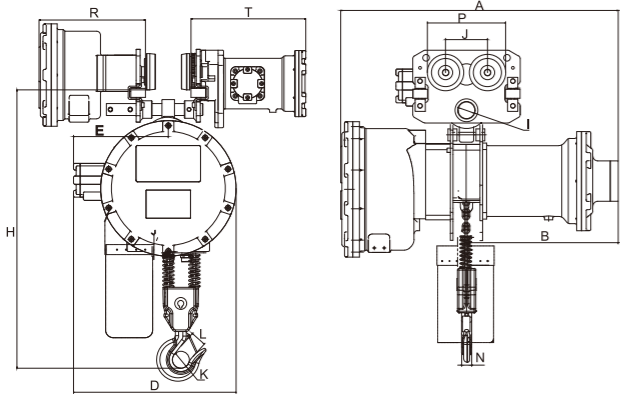

防爆标志Ex d II CT4 Gb/Ex tD A21 IP65 T130°C

Technical Parameters

型号 Type	容量 Capacity (Ton)	起升高度 Lifting Height (m)	起升速度 Lifting speed (m/min)	起升电机 Lifting Motor					操作电机 Operating Motor				
				功率 Power (kw)	转速 Rotation speed (r/min)	相位 Phases	电压 voltage (V)	频率 Frequency (Hz)	功率 Power (kw)	转速 Rotation speed (r/min)	相位 Phases	电压 voltage (V)	频率 Frequency (Hz)
OREP-C-01-01	1	3/9	6.8	1.5	1440	3	220-440	50/60	0.4	1440	3	220-440	50/60
OREP-C-02-02	2	3/9	3.4	1.5	1440	3	220-440	50/60	0.4	1440	3	220-440	50/60
OREP-C-02-01	2	3/9	6.6	3.0	1440	3	220-440	50/60	0.4	1440	3	220-440	50/60
OREP-C-03-03	3	3/9	2.2	1.5	1440	3	220-440	50/60	0.75	1440	3	220-440	50/60
OREP-C-03-02	3	3/9	3.3	3.0	1440	3	220-440	50/60	0.75	1440	3	220-440	50/60
OREP-C-03-01	3	3/9	5.6	3.0	1440	3	220-440	50/60	0.75	1440	3	220-440	50/60
OREP-C-05-02	5	3/9	2.8	3.0	1440	3	220-440	50/60	0.75	1440	3	220-440	50/60

Product Size

型号Type	H	A	B	D	E	I	J	K	L	N	P	R	T	Chain	I-BEAM
OREP-C-01-01	650	745	405	410	235	φ31	111	φ40	31	24	206	315	360	φ7.1	100-160
OREP-C-02-02	740	745	405	410	235	φ36	127	φ49	35	30	237	317	362	φ7.1	100-160
OREP-C-02-01	770	855	460	460	250	φ36	127	φ49	35	30	237	317	362	φ10.0	100-160
OREP-C-03-03	1000	745	405	410	295	φ43	140	φ59	42	35	265	320	365	φ7.1	120-180
OREP-C-03-02	940	855	460	460	290	φ43	140	φ59	42	35	265	320	365	φ11.2	120-180
OREP-C-03-01	840	855	460	460	250	φ43	140	φ59	42	35	265	320	365	φ11.2	120-180
OREP-C-05-02	1015	855	460	460	290	φ54	156	φ59	45	42	296	327	372	φ11.2	120-180

**10-32T BT4/CT4**

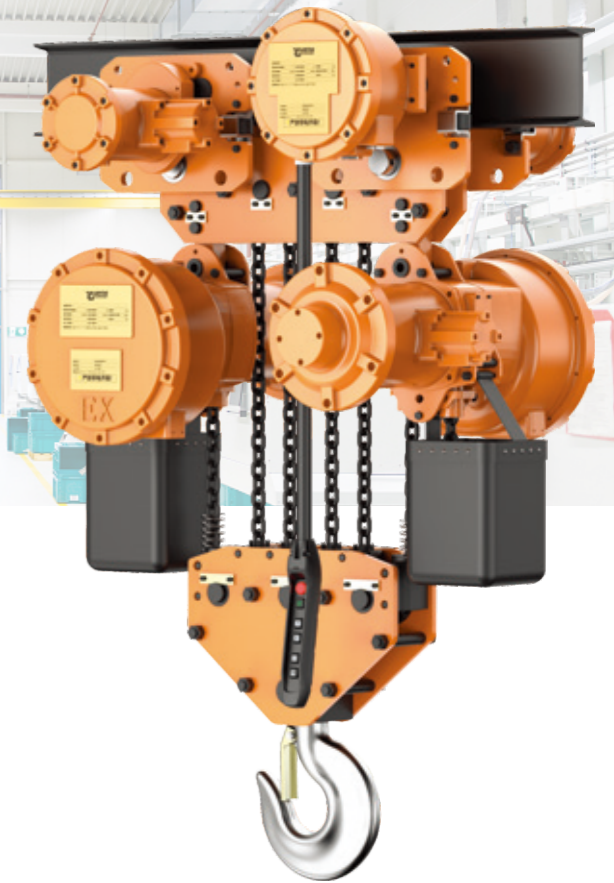
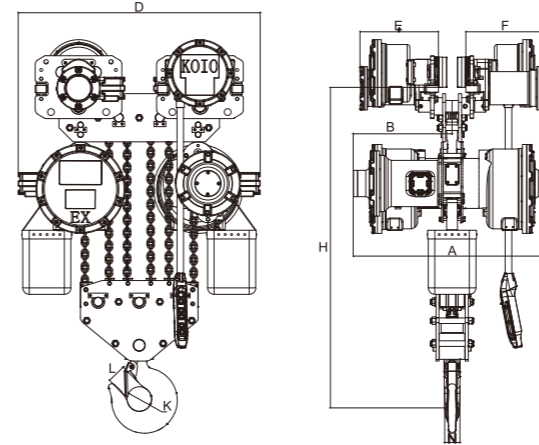

防爆标志Ex d II BT4 Gb/Ex tD A21 IP65 T130°C  
防爆标志Ex d II CT4 Gb/Ex tD A21 IP65 T130°C

Technical Parameters

型号 Type	容量 Capacity (Ton)	起升高度 Lifting Height (m)	起升速度 Lifting speed (m/min)	起升电机 Lifting Motor					移动速度 Traveling speed (m/min)	操作电机 Operating Motor				
				功率 Power (kw)	转速 Rotation speed (r/min)	相位 Phases	电压 voltage (V)	频率 Frequency (Hz)		功率 Power (kw)	转速 Rotation speed (r/min)	相位 Phases	电压 voltage (V)	频率 Frequency (Hz)
OREP-B-10-04	10	3/9	2.2	3x2	1440	3	220-440	50/60	10/20	0.75x2	1440	3	220-440	50/60
OREP-B-15-06	15	3/9	1.8	3x2	1440	3	220-440	50/60	10/20	0.75x2	1440	3	220-440	50/60
OREP-B-20-08	20	3/9	1.4	3x2	1440	3	220-440	50/60	10/20	0.75x2	1440	3	220-440	50/60
OREP-B-25-10	25	3/9	1.1	3x2	1440	3	220-440	50/60	10/20	0.75x2	1440	3	220-440	50/60
OREP-B-32-12	32	3/9	0.9	3x2	1440	3	220-440	50/60	10/20	0.75x2	1440	3	220-440	50/60
OREP-C-10-04	10	3/9	2.2	3x2	1440	3	220-440	50/60	10/20	0.75x2	1440	3	220-440	50/60
OREP-C-15-06	15	3/9	1.8	3x2	1440	3	220-440	50/60	10/20	0.75x2	1440	3	220-440	50/60
OREP-C-20-08	20	3/9	1.4	3x2	1440	3	220-440	50/60	10/20	0.75x2	1440	3	220-440	50/60
OREP-C-25-10	25	3/9	1.1	3x2	1440	3	220-440	50/60	10/20	0.75x2	1440	3	220-440	50/60
OREP-C-32-12	32	3/9	0.9	3x2	1440	3	220-440	50/60	10/20	0.75x2	1440	3	220-440	50/60

Product Size

型号Type	容量Capacity	H	A	B	D	E	F	K	L	N	工字钢I-BEAM
OREP-B-10-04	10	1200	920	460	940	376	376	φ83	68	55	150-220
OREP-B-15-06	15	1360	920	460	1120	376	376	φ115	90	72	150-220
OREP-B-20-08	20	1470	920	460	1310	376	376	φ115	90	72	150-220
OREP-B-25-10	25	1580	920	460	1500	376	376	φ142	110	85	150-220
OREP-B-32-12	32	1640	920	460	1720	376	376	φ142	110	85	150-220
OREP-C-10-04	10	1200	920	460	940	376	376	φ83	68	55	150-220
OREP-C-15-06	15	1360	920	460	1120	376	376	φ115	90	72	150-220
OREP-C-20-08	20	1470	920	460	1310	376	376	φ115	90	72	150-220
OREP-C-25-10	25	1580	920	460	1500	376	376	φ142	110	85	150-220
OREP-C-32-12	32	1640	920	460	1720	376	376	φ142	110	85	150-220

# OREP Series SUPER LOW LIFTING 超低净空式

1-5T BT4

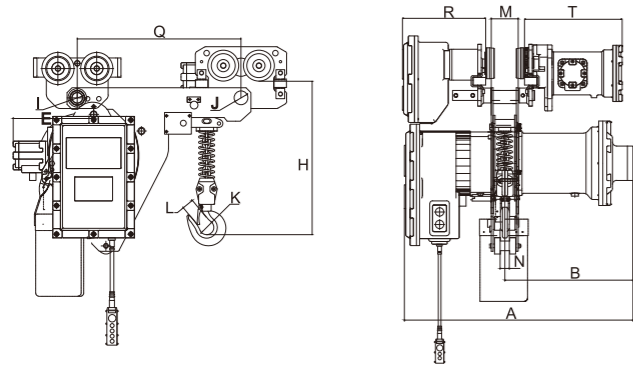

1-5T BT4

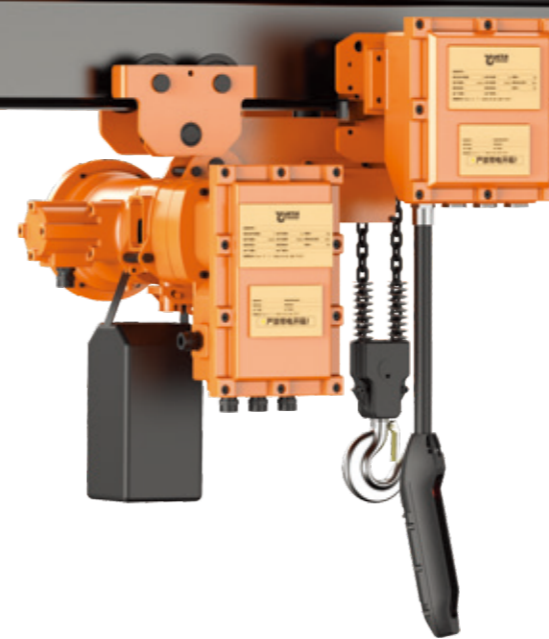
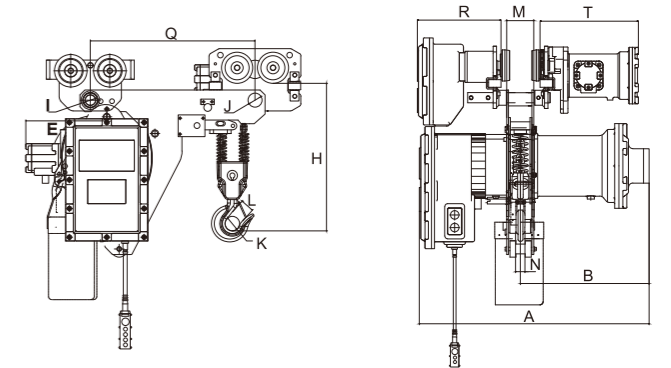

Technical Parameters

防爆标志Ex d II BT4 Gb/Ex tD A21 IP65 T130°C

型号 Type	容量 Capacity (Ton)	起升高度 Lifting Height (m)	起升速度 Lifting speed (m/min)	起升电机 Lifting Motor					操作电机 Operating Motor				
				功率 Power (kw)	转速 Rotation speed (r/min)	相位 Phases	电压 voltage (V)	频率 Frequency (Hz)	功率 Power (kw)	转速 Rotation speed (r/min)	相位 Phases	电压 voltage (V)	频率 Frequency (Hz)
OREP-BL-01-01	1	3/9	6.8	1.5	1440	3	220-440	50/60	0.4	1440	3	220-440	50/60
OREP-BL-02-02	2	3/9	3.4	1.5	1440	3	220-440	50/60	0.4	1440	3	220-440	50/60
OREP-BL-02-01	2	3/9	6.6	3.0	1440	3	220-440	50/60	0.4	1440	3	220-440	50/60
OREP-BL-03-02	3	3/9	3.3	3.0	1440	3	220-440	50/60	0.75	1440	3	220-440	50/60
OREP-BL-03-01	3	3/9	5.6	3.0	1440	3	220-440	50/60	0.75	1440	3	220-440	50/60
OREP-BL-05-02	5	3/9	2.8	3.0	1440	3	220-440	50/60	0.75	1440	3	220-440	50/60
OREP-BL-7.5-03	7.5	3/9	1.8	3.0	1440	3	220-440	50/60	0.75	1440	3	220-440	50/60

Product Size

Unit(mm)

型号Type	H	A	B	I	J	K	L	M	N	Q	R	T	Chain	工字钢I-BEAM
OREP-BL-01-01	480	700	405	φ28	φ31	φ40	31	56	24	445	300	360	φ71	100-160
OREP-BL-02-02	535	700	405	φ31	φ36	φ49	35	56	30	445.5	302	362	φ71	100-160
OREP-BL-02-01	570	825	460	φ31	φ36	φ49	35	62	30	505	302	362	φ10.0	100-160
OREP-BL-03-02	685	825	460	φ36	φ43	φ59	42	62	35	503	305	365	φ10.0	120-180
OREP-BL-03-01	640	825	460	φ43	φ43	φ59	42	74	35	526	305	365	φ11.2	120-180
OREP-BL-05-02	740	825	460	φ43	φ54	φ60	45	77	43	541	305	372	φ11.2	120-180
OREP-BL-7.5-03	900	825	460	φ43	φ54	φ83	68	77	50	571	312	372	φ11.2	120-180

Technical Parameters

防爆标志Ex d II BT4 Gb/Ex tD A21 IP65 T130°C

型号 Type	容量 Capacity (Ton)	起升高度 Lifting Height (m)	起升速度 Lifting speed (m/min)	起升电机 Lifting Motor					操作电机 Operating Motor				
				功率 Power (kw)	转速 Rotation speed (r/min)	相位 Phases	电压 voltage (V)	频率 Frequency (Hz)	功率 Power (kw)	转速 Rotation speed (r/min)	相位 Phases	电压 voltage (V)	频率 Frequency (Hz)
OREP-BL-01-01	1	3/9	6.8	1.5	1440	3	220-440	50/60	0.4	1440	3	220-440	50/60
OREP-BL-02-02	2	3/9	3.4	1.5	1440	3	220-440	50/60	0.4	1440	3	220-440	50/60
OREP-BL-02-01	2	3/9	6.6	3.0	1440	3	220-440	50/60	0.4	1440	3	220-440	50/60
OREP-BL-03-02	3	3/9	3.3	3.0	1440	3	220-440	50/60	0.75	1440	3	220-440	50/60
OREP-BL-03-01	3	3/9	5.6	3.0	1440	3	220-440	50/60	0.75	1440	3	220-440	50/60
OREP-BL-05-02	5	3/9	2.8	3.0	1440	3	220-440	50/60	0.75	1440	3	220-440	50/60
OREP-BL-7.5-03	7.5	3/9	1.8	3.0	1440	3	220-440	50/60	0.75	1440	3	220-440	50/60

Product Size

Unit(mm)

型号Type	H	A	B	I	J	K	L	M	N	Q	R	T	Chain	工字钢I-BEAM
OREP-BL-01-01	480	700	405	φ28	φ31	φ40	31	56	24	445	300	360	φ71	100-160
OREP-BL-02-02	535	700	405	φ31	φ36	φ49	35	56	30	445.5	302	362	φ71	100-160
OREP-BL-02-01	570	825	460	φ31	φ36	φ49	35	62	30	505	302	362	φ10.0	100-160
OREP-BL-03-02	685	825	460	φ36	φ43	φ59	42	62	35	503	305	365	φ10.0	120-180
OREP-BL-03-01	640	825	460	φ43	φ43	φ59	42	74	35	526	305	365	φ11.2	120-180
OREP-BL-05-02	740	825	460	φ43	φ54	φ60	45	77	43	541	305	372	φ11.2	120-180
OREP-BL-7.5-03	900	825	460	φ43	φ54	φ83	68	77	50	571	312	372	φ11.2	120-180



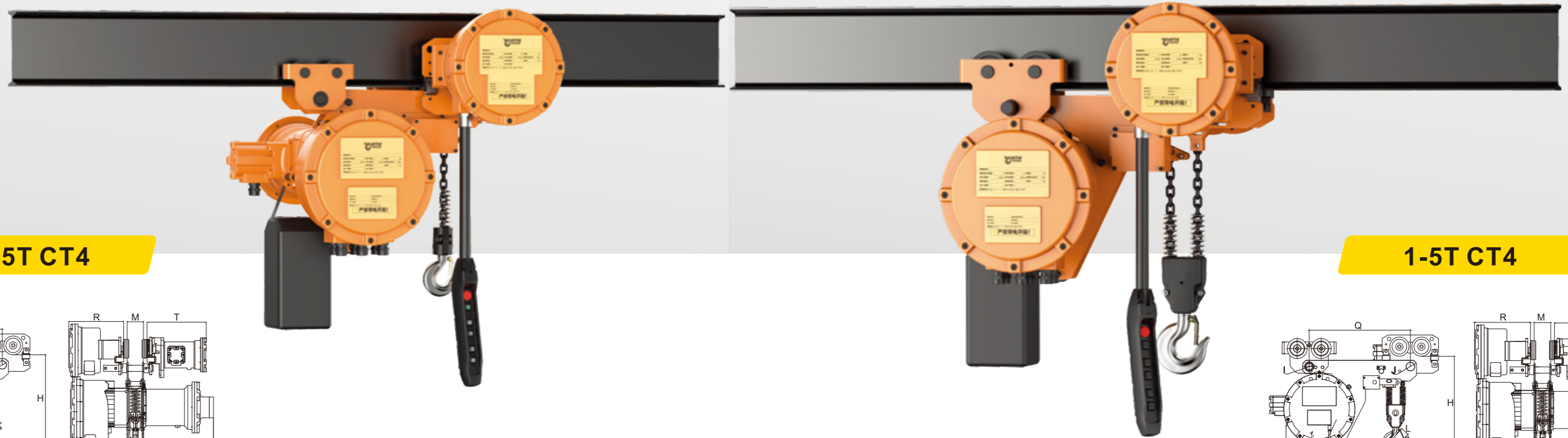

1-5T CT4

1-5T CT4

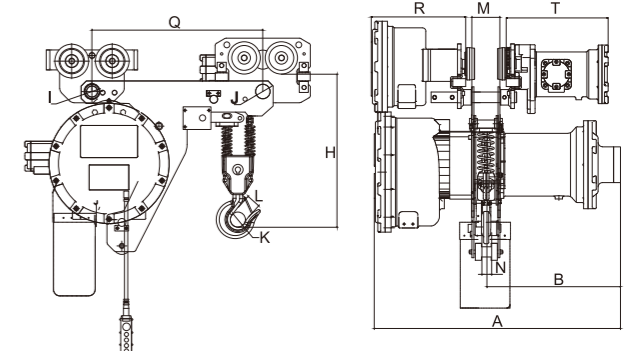
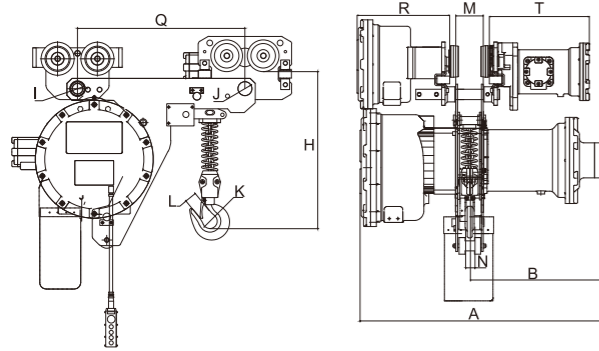

Technical Parameters

防爆标志Ex d II CT4 Gb/Ex tD A21 IP65 T130°C

型号 Type	容量 Capacity (Ton)	起升高度 Lifting Height (m)	起升速度 Lifting speed (m/min)	起升电机 Lifting Motor					操作电机 Operating Motor				
				功率 Power (kw)	转速 Rotation speed (r/min)	相位 Phases	电压 voltage (V)	频率 Frequency (Hz)	功率 Power (kw)	转速 Rotation speed (r/min)	相位 Phases	电压 voltage (V)	频率 Frequency (Hz)
OREP-CL-01-01	1	3/9	6.8	1.5	1440	3	220-440	50/60	0.4	1440	3	220-440	50/60
OREP-CL-02-02	2	3/9	3.4	1.5	1440	3	220-440	50/60	0.4	1440	3	220-440	50/60
OREP-CL-02-01	2	3/9	6.6	3.0	1440	3	220-440	50/60	0.4	1440	3	220-440	50/60
OREP-CL-03-02	3	3/9	3.3	3.0	1440	3	220-440	50/60	0.75	1440	3	220-440	50/60
OREP-CL-03-01	3	3/9	5.6	3.0	1440	3	220-440	50/60	0.75	1440	3	220-440	50/60
OREP-CL-05-02	5	3/9	2.8	3.0	1440	3	220-440	50/60	0.75	1440	3	220-440	50/60
OREP-CL-7.5-03	7.5	3/9	1.8	3.0	1440	3	220-440	50/60	0.75	1440	3	220-440	50/60

Product Size

Unit(mm)

型号Type	H	A	B	I	J	K	L	M	N	Q	R	T	Chain	工字钢I-BEAM
OREP-CL-01-01	480	745	405	φ28	φ31	φ40	31	56	24	445	315	360	φ7.1	100-160
OREP-CL-02-02	535	745	405	φ31	φ36	φ49	35	56	30	445.5	317	362	φ7.1	100-160
OREP-CL-02-01	570	855	460	φ31	φ36	φ49	35	62	30	505	317	362	φ10.0	100-160
OREP-CL-03-02	685	855	460	φ36	φ43	φ59	42	62	35	503	320	365	φ10.0	120-180
OREP-CL-03-01	640	855	460	φ43	φ43	φ59	42	74	35	526	320	365	φ11.2	120-180
OREP-CL-05-02	740	855	460	φ43	φ54	φ60	45	77	43	541	327	372	φ11.2	120-180
OREP-CL-7.5-03	900	855	460	φ43	φ54	φ83	68	77	50	571	327	372	φ11.2	120-180

Technical Parameters

防爆标志Ex d II CT4 Gb/Ex tD A21 IP65 T130°C

型号 Type	容量 Capacity (Ton)	起升高度 Lifting Height (m)	起升速度 Lifting speed (m/min)	起升电机 Lifting Motor					操作电机 Operating Motor				
				功率 Power (kw)	转速 Rotation speed (r/min)	相位 Phases	电压 voltage (V)	频率 Frequency (Hz)	功率 Power (kw)	转速 Rotation speed (r/min)	相位 Phases	电压 voltage (V)	频率 Frequency (Hz)
OREP-CL-01-01	1	3/9	6.8	1.5	1440	3	220-440	50/60	0.4	1440	3	220-440	50/60
OREP-CL-02-02	2	3/9	3.4	1.5	1440	3	220-440	50/60	0.4	1440	3	220-440	50/60
OREP-CL-02-01	2	3/9	6.6	3.0	1440	3	220-440	50/60	0.4	1440	3	220-440	50/60
OREP-CL-03-02	3	3/9	3.3	3.0	1440	3	220-440	50/60	0.75	1440	3	220-440	50/60
OREP-CL-03-01	3	3/9	5.6	3.0	1440	3	220-440	50/60	0.75	1440	3	220-440	50/60
OREP-CL-05-02	5	3/9	2.8	3.0	1440	3	220-440	50/60	0.75	1440	3	220-440	50/60
OREP-CL-7.5-03	7.5	3/9	1.8	3.0	1440	3	220-440	50/60	0.75	1440	3	220-440	50/60

Product Size

Unit(mm)

型号Type	H	A	B	I	J	K	L	M	N	Q	R	T	Chain	工字钢I-BEAM
OREP-CL-01-01	480	745	405	φ28	φ31	φ40	31	56	24	445	315	360	φ7.1	100-160
OREP-CL-02-02	535	745	405	φ31	φ36	φ49	35	56	30	445.5	317	362	φ7.1	100-160
OREP-CL-02-01	570	855	460	φ31	φ36	φ49	35	62	30	505	317	362	φ10.0	100-160
OREP-CL-03-02	685	855	460	φ36	φ43	φ59	42	62	35	503	320	365	φ10.0	120-180
OREP-CL-03-01	640	855	460	φ43	φ43	φ59	42	74	35	526	320	365	φ11.2	120-180
OREP-CL-05-02	740	855	460	φ43	φ54	φ60	45	77	43	541	327	372	φ11.2	120-180
OREP-CL-7.5-03	900	855	460	φ43	φ54	φ83	68	77	50	571	327	372	φ11.2	120-180

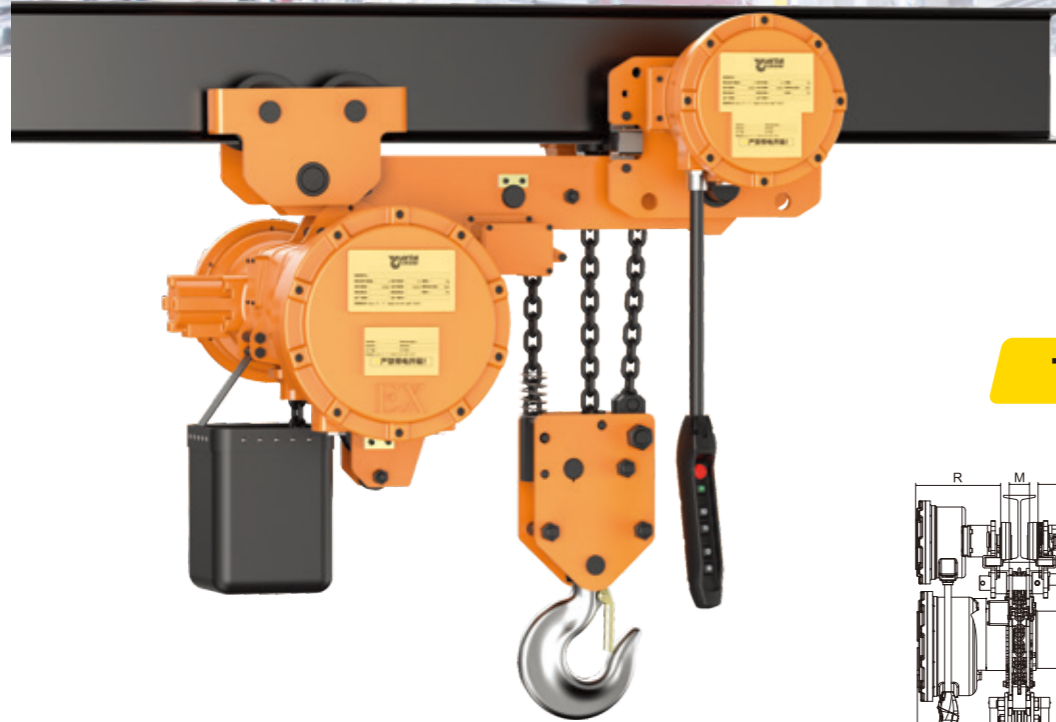

**7.5T BT4/CT4**

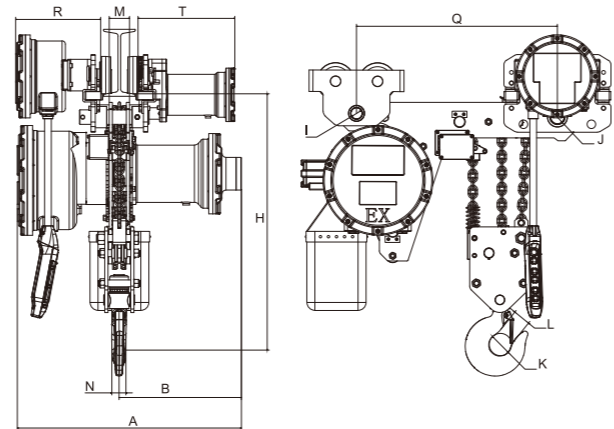

防爆标志Ex d II BT4 Gb/Ex tD A21 IP65 T130°C  
 防爆标志Ex d II CT4 Gb/Ex tD A21 IP65 T130°C

Technical Parameters

型号 Type	容量 Capacity (Ton)	起升高度 Lifting Height (m)	起升速度 Lifting speed (m/min)	起升电机 Lifting Motor					操作电机 Operating Motor				
				功率 Power (kw)	转速 Rotation speed (r/min)	相位 Phases	电压 voltage (V)	频率 Frequency (Hz)	功率 Power (kw)	转速 Rotation speed (r/min)	相位 Phases	电压 voltage (V)	频率 Frequency (Hz)
OREP-BL-7.5-03	7.5	3/9	1.8	3.0	1440	3	220-440	50/60	0.75	1440	3	220-440	50/60
OREP-CL-7.5-03	7.5	3/9	1.8	3.0	1440	3	220-440	50/60	0.75	1440	3	220-440	50/60

Product Size

Unit(mm)

型号Type	H	A	B	I	J	K	L	M	N	Q	R	T	Chain	工字钢I-BEAM
OREP-BL-7.5-03	900	825	460	φ43	φ54	φ83	68	77	50	751	312	372	φ11.2	120-180
OREP-CL-7.5-03	900	855	460	φ43	φ54	φ83	68	77	50	751	327	372	φ11.2	120-180

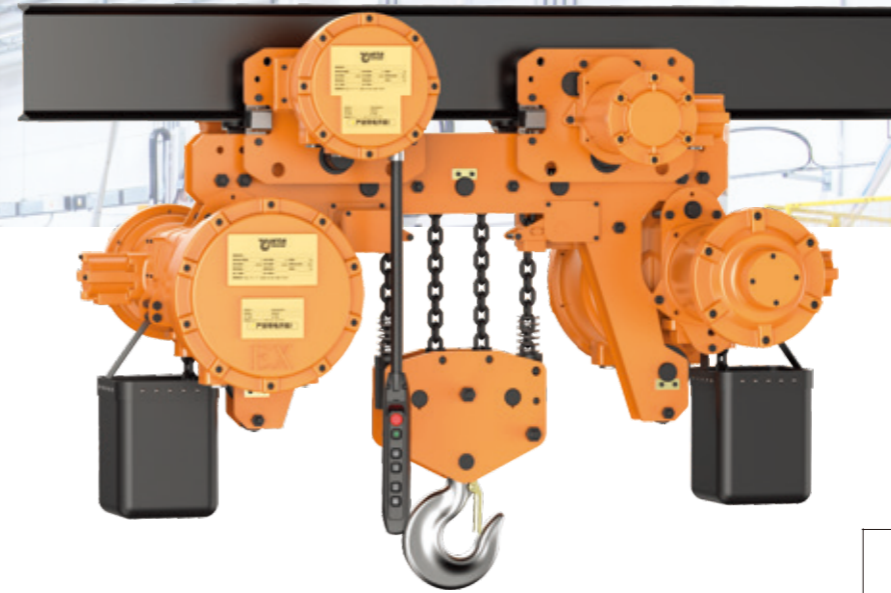

**10-25T BT4/CT4**

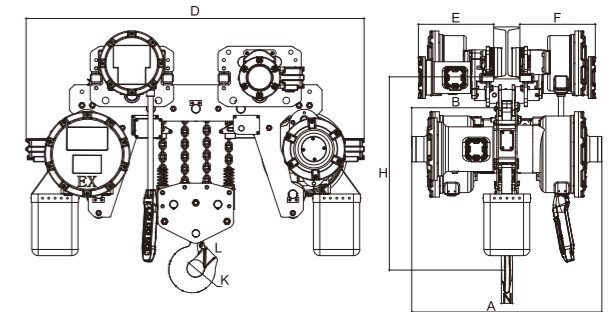

防爆标志Ex d II BT4 Gb/Ex tD A21 IP65 T130°C  
 防爆标志Ex d II CT4 Gb/Ex tD A21 IP65 T130°C

Technical Parameters

型号 Type	容量 Capacity (Ton)	起升高度 Lifting Height (m)	起升速度 Lifting speed (m/min)	起升电机 Lifting Motor					移动速度 Traveling speed (m/min)	操作电机 Operating Motor				
				功率 Power (kw)	转速 Rotation speed (r/min)	相位 Phases	电压 voltage (V)	频率 Frequency (Hz)		功率 Power (kw)	转速 Rotation speed (r/min)	相位 Phases	电压 voltage (V)	频率 Frequency (Hz)
OREP-BL-10-04	10	3/9	2.2	3x2	1440	3	220-440	50/60	10/20	0.75x2	1440	3	220-440	50/60
OREP-BL-15-06	15	3/9	1.8	3x2	1440	3	220-440	50/60	10/20	0.75x2	1440	3	220-440	50/60
OREP-BL-20-08	20	3/9	1.4	3x2	1440	3	220-440	50/60	10/20	0.75x2	1440	3	220-440	50/60
OREP-BL-25-10	25	3/9	1.1	3x2	1440	3	220-440	50/60	10/20	0.75x2	1440	3	220-440	50/60
OREP-CL-10-04	10	3/9	2.2	3x2	1440	3	220-440	50/60	10/20	0.75x2	1440	3	220-440	50/60
OREP-CL-15-06	15	3/9	1.8	3x2	1440	3	220-440	50/60	10/20	0.75x2	1440	3	220-440	50/60
OREP-CL-20-08	20	3/9	1.4	3x2	1440	3	220-440	50/60	10/20	0.75x2	1440	3	220-440	50/60
OREP-CL-25-10	25	3/9	1.1	3x2	1440	3	220-440	50/60	10/20	0.75x2	1440	3	220-440	50/60

Product Size

Unit(mm)

型号Type	容量Capacity	H	A	B	D	E	F	K	L	N	工字钢I-BEAM
OREP-BL-10-04	10	880	920	460	1620	376	376	φ83	68	55	150-220
OREP-BL-15-06	15	1100	920	460	1840	376	376	φ115	90	72	150-220
OREP-BL-20-08	20	1180	920	460	2050	376	376	φ115	90	72	150-220
OREP-BL-25-10	25	1280	920	460	2265	376	376	φ142	110	85	150-220
OREP-CL-10-04	10	880	920	460	1620	376	376	φ83	68	55	150-220
OREP-CL-15-06	15	1100	920	460	1840	376	376	φ115	90	72	150-220
OREP-CL-20-08	20	1180	920	460	2050	376	376	φ115	90	72	150-220
OREP-CL-25-10	25	1280	920	460	2265	376	376	φ142	110	85	150-220

### Double Speed Hoist Specifications

型号 Type	容量 Capacity (Ton)	起升速度 Lifting speed (m/min)	起升电机 Lifting Motor					移动速度 Traveling speed (m/min)	操作电机 Operating Motor				
			功率 Power (kw)	转速 Rotation speed (r/min)	相位 Phases	电压 voltage (V)	频率 Frequency (Hz)		功率 Power (kw)	转速 Rotation speed (r/min)	相位 Phases	电压 voltage (V)	频率 Frequency (Hz)
OREP-B-01-01D	1	6.8/2.3	1.5	1440/480	3	220-440	50/60	10/3.3	0.4	1440/480	3	220-440	50/60
OREP-B-02-02D	2	3.4/1.1	1.5	1440/480	3	220-440	50/60	10/3.3	0.4	1440/480	3	220-440	50/60
OREP-B-02-01D	2	6.6/2.2	3	1440/480	3	220-440	50/60	10/3.3	0.4	1440/480	3	220-440	50/60
OREP-B-03-03D	3	2.3/0.8	1.5	1440/480	3	220-440	50/60	10/3.3	0.75	1440/480	3	220-440	50/60
OREP-B-03-02D	3	3.3/1.1	3	1440/480	3	220-440	50/60	10/3.3	0.75	1440/480	3	220-440	50/60
OREP-B-03-01D	3	5.6/1.9	3	1440/480	3	220-440	50/60	10/3.3	0.75	1440/480	3	220-440	50/60
OREP-B-05-02D	5	2.8/0.9	3	1440/480	3	220-440	50/60	10/3.3	0.75	1440/480	3	220-440	50/60
OREP-B-7.5-03D	7.5	1.8/0.6	3x2	1440/480	3	220-440	50/60	10/3.3	0.75	1440/480	3	220-440	50/60
OREP-B-10-04D	10	2.8/0.9	3x2	1440/480	3	220-440	50/60	10/3.3	0.75x2	1440/480	3	220-440	50/60
OREP-B-15-06D	15	1.8/0.6	3x2	1440/480	3	220-440	50/60	10/3.3	0.75x2	1440/480	3	220-440	50/60
OREP-B-20-08D	20	1.4/0.5	3x2	1440/480	3	220-440	50/60	10/3.3	0.75x2	1440/480	3	220-440	50/60
OREP-B-25-10D	25	1.1/0.4	3x2	1440/480	3	220-440	50/60	10/3.3	0.75x2	1440/480	3	220-440	50/60
OREP-B-32-12D	32	0.9/0.3	3x2	1440/480	3	220-440	50/60	10/3.3	0.75x2	1440/480	3	220-440	50/60
OREP-C-01-01D	1	6.8/2.3	1.5	1440/480	3	220-440	50/60	10/3.3	0.4	1440/480	3	220-440	50/60
OREP-C-02-02D	2	3.4/1.1	1.5	1440/480	3	220-440	50/60	10/3.3	0.4	1440/480	3	220-440	50/60
OREP-C-02-01D	2	6.6/2.2	3	1440/480	3	220-440	50/60	10/3.3	0.4	1440/480	3	220-440	50/60
OREP-C-03-03D	3	2.3/0.8	1.5	1440/480	3	220-440	50/60	10/3.3	0.75	1440/480	3	220-440	50/60
OREP-C-03-02D	3	3.3/1.1	3	1440/480	3	220-440	50/60	10/3.3	0.75	1440/480	3	220-440	50/60
OREP-C-03-01D	3	5.6/1.9	3	1440/480	3	220-440	50/60	10/3.3	0.75	1440/480	3	220-440	50/60
OREP-C-05-02D	5	2.8/0.9	3	1440/480	3	220-440	50/60	10/3.3	0.75	1440/480	3	220-440	50/60
OREP-C-7.5-03D	7.5	1.8/0.6	3x2	1440/480	3	220-440	50/60	10/3.3	0.75	1440/480	3	220-440	50/60
OREP-C-10-04D	10	2.8/0.9	3x2	1440/480	3	220-440	50/60	10/3.3	0.75x2	1440/480	3	220-440	50/60
OREP-C-15-06D	15	1.8/0.6	3x2	1440/480	3	220-440	50/60	10/3.3	0.75x2	1440/480	3	220-440	50/60
OREP-C-20-08D	20	1.4/0.5	3x2	1440/480	3	220-440	50/60	10/3.3	0.75x2	1440/480	3	220-440	50/60
OREP-C-25-10D	25	1.1/0.4	3x2	1440/480	3	220-440	50/60	10/3.3	0.75x2	1440/480	3	220-440	50/60
OREP-C-32-12D	32	0.9/0.3	3x2	1440/480	3	220-440	50/60	10/3.3	0.75x2	1440/480	3	220-440	50/60

