



# YUANTAI CRANE

## QD Double Girder Overhead Crane Specification



- Compact structure, new style, beautiful shape
- Good technics, long service life
- Large load capacity, high working duty
- Stable and flexible operation, safe and reliable
- Wide application, high performance /price ratio

## Part 1 Introduction

### Overall Features

- (1) Compact structure, new style, beautiful shape;
- (2) Good technics, long service life;
- (3) Large load capacity, high working duty;
- (4) Stable and flexible operation, safe and reliable;
- (5) Wide application, high performance/price ratio.



### Supply Scope

Lifting capacity 5t-550t, span 10.5m-31.5m, lifting height 1m-30m, working duty is medium (A5, A6). Also supply non-standard products according to your requirements.

Note:

a) Lifting Capacity:

5T	10T	16/3.2T	20/5T	32/5T	50/10T	75/20T	100/20T	125/32T	150/30T
160/32T	200/50T	250/50T	300/75T	350/80T	400/80T	450/100T	500/100T	550/100T	

b) Span:

10.5M	13.5M	16.5M	19.5M	22.5M	25.5M	28.5M	31.5M
-------	-------	-------	-------	-------	-------	-------	-------

c) Working Duty:

A5(Used in working not so frequency, such as general machining and assembly workshop)

A6 (Used in much more frequency work, such as auxiliary hoisting in metallurgy and casting workshop)

A7 (Used in busy working and the hoisting of melted hot metal)

### Applications

- (1) Applied to materials handling between fixed span, and it's one of the most widely used crane with the largest number of varieties of different specifications.
- (2) Widely used in carrying, assemble and unassemble of general weights, and also can equipped with various special hoists for special operation.
- (3) Forbid to use in the conditions as easily combustible, explosive, corrosive (acid, alkali, plating, steam, etc.).

### Conditions

Working ambient  $-25^{\circ}\text{C} \sim +40^{\circ}\text{C}$ , moisture  $\leq 85\%$ , altitude below 1000 meters, power supply 380V, 50Hz, 3phases (Adjustable according to customer's different requirement).

### Specification and Description

Note: For example, QD5t-10.5 m means general overhead crane with lifting capacity 5t and span 10.5m.

### Structure and Characteristics

Mainly consists of bridge, trolley, crane traveling mechanism and electrical system, etc.

There are three main operating mechanisms: lifting mechanism, trolley traveling mechanism and crane traveling mechanism. And each of them is equipped with separate motors for their own drive. For 5 ton and 10 ton cranes, normally single hook crane and only have one set of lifting mechanism. For 16/3.2~50/10t cranes, there are two separate main and auxiliary lifting mechanism with two hook.

Main hook is used for lifting heavy objects and auxiliary hook can be used for lighter ones. And the auxiliary hook can also be used to help the main hook tip and turn over workpiece.

Should pay more attention that never allow two hook lifting two objects at the same time. The weight of the object is forbid to surpass the rated lifting capacity of main hook when they work together.

## ■ Bridge Frame

Consists of main girder, end beam, walkway, railing, overhaul crane cage, cab and its platform, etc.

### ▣ Main Girder

1. Double main girder, welded box girder and camber meet national standard
2. Steel material is Q235B or Q345B (similar to foreign steel type Fe37 or Fe52).
3. Main weld adopt Lincoln welding and nondestructive test.

### ▣ End Beam

1. Main end beam is rigid connection. The middle of the two end beam is detachable connected by bolts.
2. The whole bridge is separate into two pieces for transportation and installation.



### ▣ Others

1. Lay the track on the upper cover plate for trolley traveling.
2. Install the crane traveling mechanism on the side of walkway which connect with main girder.
3. Install the trolley sliding wire on the other side.
4. There is railing on the outboard of walkway in order to ensure the operator safety during maintenance.
5. The cab usually hangs beneath the bridge with electrical control equipment in it and mainly for operator use.

## ■ Trolley

Consists of trolley frame, lifting mechanism and trolley traveling mechanism, etc.

▣ Trolley Frame

1. Welded of steel plate with high intensity and strong rigidity.
2. Equipped with lifting mechanism and trolley traveling mechanism.

▣ Lifting Mechanism

1. One set of independent driving device for single hook and two separate driving device for double hook (main and auxiliary).
2. Lifting mechanism working principle, through high speed rotating of YZR type crane special motor, and gear coupling drive involute gear reducer. Then the low speed shaft of reducer turn the wire rope drum. As long as the control of motors and its positive and negative rotation, can achieve the lifting function of the hook.
3. In order to ensure the security and reliable of lifting mechanism, the brake is installed on the high speed shaft of reducer. And the load limiter is installed on the bearing pedestal which supports the drum to avoid overload. The mechanical drawing as follows:

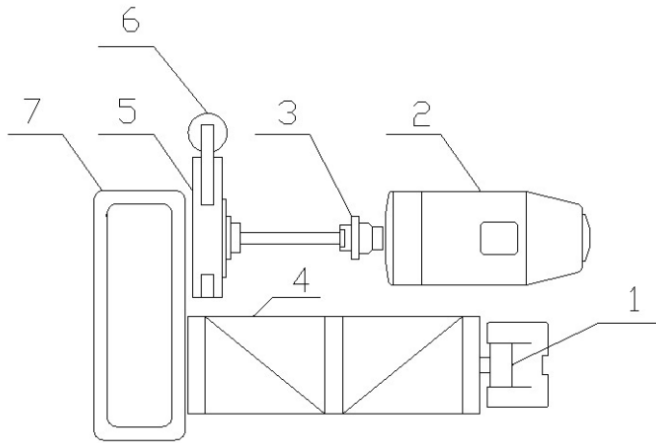

1. Main overload limitation;
2. Main lifting motor;
3. Main lifting gear coupling;
4. Main lifting drum;
5. Main lifting brake wheel coupling;
6. Main lifting brake;
7. Main lifting reducer

▣ Trolley Traveling Mechanism

1. Trolley traveling mechanism working principle, the involute vertical gear reducer driven by motor. The low speed shaft of reducer connects to active wheel of trolley frame in the way of centralized driving. The motor adopt double-output gear and there is a brake on one end of it.
2. There are four wheels installed under the trolley. Two of them are active wheels and the others are driven wheels. Driving devices include 1. Motor; 2. Brake; 3. Reducer; 4. Compensating shaft; 5. Coupling; 6. Wheels, etc. are shown in the mechanical drawing as follows:

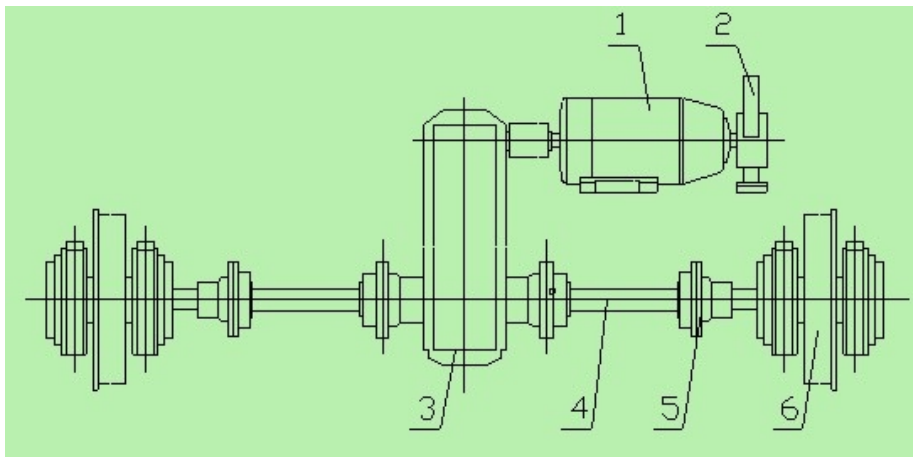

## ■ Crane Traveling Mechanism

1. There are four traveling wheels installed on each side of the two end beams. Two of them are active wheels and the others are driven ones. The driving device of active wheels is installed on the walkway. Here adopt two sets of symmetrical independent driving devices and we call it respectively driven.
2. The reducer adopts circular-arc gear one of which load capacity is higher than involute gear reducer of the same type. All of the mechanisms adopt rolling bearing with A.C. electromagnetic block brake.
3. Driving devices include 1. Reducer; 2. Motor; 3. Brake; 4. Coupling; 5. Coupling; 6. Wheels, etc are shown in the mechanical drawing as follows:

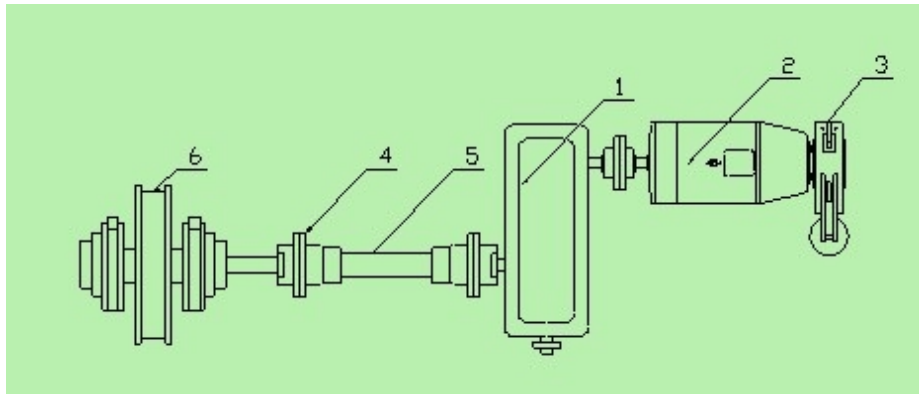

4. The connection of the mechanism parts all adopt gear coupling. In this way, it can work well by gear coupling compensated even there is an error caused in manufacture and installation or deflection between the parts caused by bridge deformation when loading.
5. Active and driven wheel axle support on the angular bearing box for easy assembly and maintenance.

### ▣ Trolley Traveling Mechanism

1. Trolley traveling mechanism working principle, the involute vertical gear reducer driven by motor. The low speed shaft of reducer connects to active wheel of trolley frame in the way of centralized driving. The motor adopt double-output gear and there is a brake on one end of it.
2. There are four wheels installed under the trolley. Two of them are active wheels and the others are driven wheels. Driving devices include 1. Motor; 2. Brake; 3. Reducer; 4. Compensating shaft; 5. Coupling; 6. Wheels, etc. are shown in the mechanical drawing as follows:

## ■ Other Equipment

### 1. Bumper

The crane bumpers are installed on the both ends of the two end beams. The trolley bumpers are installed under the trolley frame, and usually polyurethane buffer. Also can choose according to customer's requirement. Use to reduce the collision possibility between two cranes within the same span or the impact influence caused when trolley reach the limit position at both ends.



### 2. Crane Conductor Wire Frame

In order to prevent the hook or wire rope collide with high voltage supply when trolley run at the limiting position, the crane conductor wire frame is installed on the end close to power supply under the two main girder of the bridge.

### 3. Crane Pantograph

The pantograph is installed on the bottom of main girder. The power line is installed in the three sets of current collector to supply the power of the whole crane.

## ■ Electrical System

1. Electric control box layout is reasonable, easy to repair
2. Security trolley line or angle steel trolley line
3. External cable are equipped with mark line number
4. Trolley moving power is supplied by flat cable
5. The conductor is I steel or C shape sliding line
6. Safety sliding touch line with high conductive rate and low pressure drop; current collector with high speed.
7. Lifting and crane can be independently controlled; also can work separately or together.



### ▣ Limit and Safety Switch

1. Crane traveling, trolley traveling and lifting mechanism are all equipped with limit switches to limit the travel distance of every mechanism.
2. The circuit will be cut off when the limit switch works, then the mechanism shut down. It will move in the opposite direction when switch on the power again. Thus, ensure the safety.
3. In order to prevent the operators and maintenance staff from the accident, the safety switch is installed on the access door of the walkway which lead the way from cab to bridge, and also on the railing which lead to end beam.

### ▣ Operation Mode

1. Cab control and ground control
2. Special cabin for bridge crane or capsule driver room, open vision, comfortable operation.
3. The cable have open style, close style, can fixed on left or right
4. The cab hangs under the side walkway of crane bridge close to end beam. Inside of it include control equipment of each mechanism, distribution board, emergency switch and bell push button, etc.
5. Ground control (wire or remote), without professional driver
6. Choose according to customer's different requirements



### ▣ Optional Functions

1. Speed governing of each operating mechanism (1:10 or more)
2. Overload limiter, alarm display, load weighing and display
3. Height limiter
4. Hook spur changes of main and auxiliary hook for single trolley
5. Central lubrication
6. PLC control, fault detection, display records and print system



## Part 2 Drawing

### Overall Mechanical Drawings

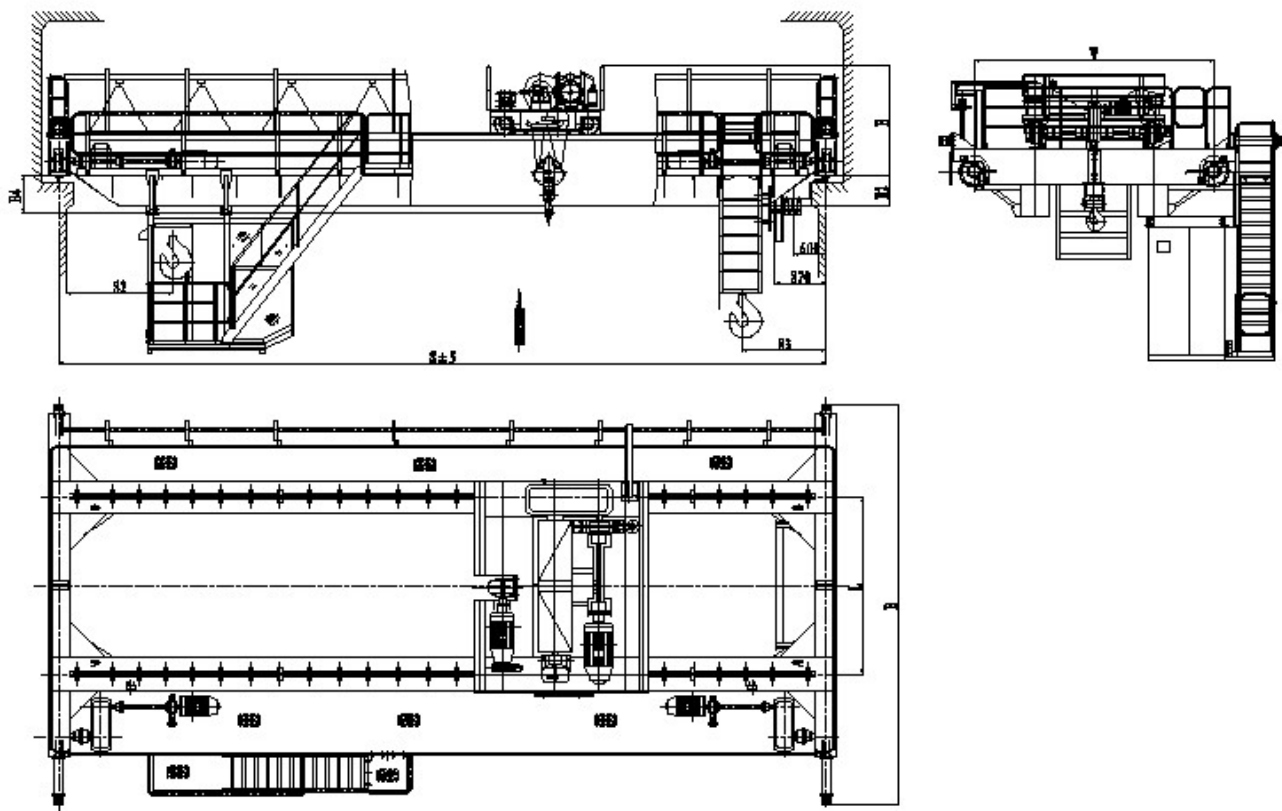

## Part 3 Parameters

QD Overhead Crane with Hook 5t									
Span	S (m)	10.5	13.5	16.5	19.5	22.5	25.5	28.5	31.5

Lifting height	m	16	16	16	16	16	16	16	16
Lifting speed	m/min	12.5	12.5	12.5	12.5	12.5	12.5	12.5	12.5
Trolley speed	m/min	37.2	37.2	37.2	37.2	37.2	37.2	37.2	37.2
Crane speed	m/min	90.7	90.7	90.7	90.7	90.7	91.9	91.9	91.9
Lifting motor	kw	13	13	13	13	13	13	13	13
Trolley motor	kw	1.8	1.8	1.8	1.8	1.8	1.8	1.8	1.8

Total weight	kg	11830	13670	15565	18200	20650	25040	28130	31080
Max Wheel Load	KN	72	78	84	92	97	109	117	125
Track		P43	P43	P43	P43	P43	P43	P43	P43

Main dimension	mm	10.5	13.5	16.5	19.5	22.5	25.5	28.5	31.5
Rail top to main top	H1	1763	1763	1763	1763	1763	1763	1763	1763
Rail top to hook centre	H2	71	71	71	71	71	71	71	71
Wheel base	W	3400	3400	3550	3550	3550	5000	5000	5000
Crane width	B	5054	5054	5204	5204	5204	5948	5948	5948
Hook left limitation	S1	800	800	800	800	800	800	800	800
Hook right limitation	S2	1250	1250	1250	1250	1250	1250	1250	1250
Trolley gauge	K	1400	1400	1400	1400	1400	1400	1400	1400

QD Overhead Crane with Hook 10t									
Span	S (m)	10.5	13.5	16.5	19.5	22.5	25.5	28.5	31.5

Lifting height	m	16	16	16	16	16	16	16	16
Lifting speed	m/min	8.5	8.5	8.5	8.5	8.5	8.5	8.5	8.5
Trolley speed	m/min	43.8	43.8	43.8	43.8	43.8	43.8	43.8	43.8
Crane speed	m/min	90.7	90.7	90.7	91.9	91.9	84.7	84.7	84.7
Lifting motor	kw	17	17	17	17	17	17	17	17
Trolley motor	kw	2.5	2.5	2.5	2.5	2.5	2.5	2.5	2.5

Total weight	kg	13640	15520	18350	20340	22750	27140	30530	33620
Max Wheel Load	KN	101	108	117	122	130	140	150	160
Track		P43	P43	P43	P43	P43	P43	P43	P43

Main dimension	mm	10.5	13.5	16.5	19.5	22.5	25.5	28.5	31.5
Rail top to main top	H1	1876	1876	1876	1876	1876	1926	1926	1926
Rail top to hook centre	H2	602	602	602	602	602	552	552	552
Wheel base	W	4050	4050	4050	4050	4050	5000	5000	5000
Crane width	B	5704	5704	5704	5882	5882	5948	5948	5948
Hook left limitation	S1	1050	1050	1050	1050	1050	1050	1050	1050
Hook right limitation	S2	1300	1300	1300	1300	1300	1300	1300	1300
Trolley gauge	K	2000	2000	2000	2000	2000	2000	2000	2000

Note: Control mode for cab operation



## ■ Part 4 Cautions of Safe Operation

1. Must not lift weights exceed the rated lifting capacity.
2. Strictly prohibit goods lifting overhead the human beings.
3. When lifting overhead, the hook position must not less than one person's height.
4. Strictly prohibit obliquely hanging and lift the objects buried in the ground.
5. Must not brake through motor's sudden reversal. Only permit when accident happens.
6. Must send warning signal before each operation.
7. Should consider the brake ability before lifting the weights close to the rated load in order to ensure safety.
8. Before driver leave the cab, the crane must be placed to the fixed park position, with nothing on the hook, every control handle at zero position and cut off the main switch.
9. Strictly obey the safety requirement of every factory, mines and the department concerned.



## Henan Yuantai Crane Machinery Import&Export Co.,Ltd.

Address:Henghua Business Building 712,Garden Road,Zhengzhou,Henan,China.

Tel: 86-371-65760776

Fax: 86-371-65760775

Web: [www.ytcrane.com](http://www.ytcrane.com)

Email: [yuantai@ytcrane.com](mailto:yuantai@ytcrane.com)



**Tips:**

You can use the phone dimensional code recognition software to scan the right side of the two-dimensional code, to quickly and easily access our web site for more information.